



Historical Review Commission

June 10, 2021

Regular Meeting

Minutes

4:00 PM

CALL TO ORDER

Attendee Name	Title	Status	Arrived
Matthew T. Starr	Mayor, Chairman	Excused	
Austin Swallow	Member	Present	
Robert Drews	Member	Present	
Jeffrey Scott Ulery	Member	Excused	
Richard Dzik	Safety-Service Director	Present	
Eric Diehl	Alt. Member	Excused	
Todd Hawkins	Alt. Member	Remote	4:03 PM
Sibley Poland	Member	Present	
Lacey Filkins	Member	Present	

Others in attendance: Lacie Blankenhorn, City Development Services Manager; P. Rob. Broeren, City Law Director; Emma Davis; Greg Lonergan (via Zoom); Stacey Varner

MINUTES APPROVAL

- Historical Review Commission - Regular Meeting - Jul 9, 2020 4:00 PM

RESULT:	ACCEPTED [UNANIMOUS]
MOVER:	Robert Drews, Member
SECONDER:	Austin Swallow, Member
AYES:	Swallow, Drews, Dzik, Hawkins, Poland, Filkins
EXCUSED:	Starr, Ulery, Diehl

HRC-ITEM NUMBERS

- 2021-HRC-16 : 111 High ST Courthouse Accessible Entry & Annex Building Renovations

Development Services Manager, Lacie Blankenhorn introduced the first case. 2021-HRC-16 - 111 E High ST - Courthouse Accessible Entry & Annex Building Renovations: The Knox County Commissioners seeks to add an accessible entry to the main courthouse, upgrade sidewalks and landscaping. Additionally, they seek to renovate the courthouse's annex building with new paint, a new roof, and new doors and windows.

Greg Lonergan (sworn in) - reviewed with the Commission the presentation that was submitted with the application showing the proposed roofing, windows, and doors for the annex building. The vinyl windows will be replaced with aluminum covered wood windows. The center doorway is proposed to be removed and replaced with a window. They don't think the door was original. The sign post will be removed. A window infill example on the opposite side was shown. The County has brick that they think will match exactly. The doors will be replaced with Pella wood doors. Landscaping will be placed in front of the gas meter. The annex entry does not meet ADA. The slab will be raised to remove the existing step and make is ADA accessible. A tree will be removed, as they feel it is too close to the building foundation. The sidewalk arrangement will be aligned for a more direct route.

The current accessible entrance to the courthouse is through a basement entrance off of the alley on the West side, past the dumpster. The path is not ideal or appropriate and not used for the general public. The request is to convert the South window on the East side of courthouse to a door with an accessible ramp. Some bushes will be removed. The wall below the window will be removed to accommodate the opening for the ramp. Handicap parking is adjacent to the opening. This entrance will allow for all to pass through the standard security checkpoint. The middle of the ramp will accommodate landscaping. Details of the windows, doors, and hardware was provided in the application packet.

There was no one else present to contribute, nor was there any written or verbal communication about the request through the Development Services Manager.

Mr. Dzik added, it looks like they are doing a lot of improvements to maintain what exists or to bring back some historic features.

Mr. Broeren said he has spent some time in the annex. The windows were very drafty.

RESULT:	ACCEPT [UNANIMOUS]
MOVER:	Austin Swallow, Member
SECONDER:	Lacey Filkins, Member
AYES:	Swallow, Drews, Dzik, Hawkins, Poland, Filkins
EXCUSED:	Starr, Ulery, Diehl

- 2021-HRC-14 : 306 E Gambier ST - Garage

Development Services Manager, Lacie Blankenhorn introduced the second case. 2021-HRC-14 - 306 E Gambier ST - a garage: Mr. Varner seeks a Certificate of Appropriateness to construct a 26' wide x 24' deep garage. His primary design has the pediment of the roof facing East/West toward South Park ST. A variance is being requested from the Board of Zoning Appeals to determine the exact location of the garage on the property which will determine the location of the pediment either East/West or South and attached to the home. See accompanying documents for further details.

Stacey Varner (sworn in) - explained he purchased the home in October of last year. He contacted Lacie prior to the purchase to research if a garage could be built. She explained the processes to him. There is a nice flowering tree and mature flowering rose bush at the Southwest corner of the house that he would like to keep. Both plants would have to be destroyed to attach the garage. By detaching the garage and placing it 2' from the rear property line and along the Park ST property line, in line with the existing home, the plants can be saved. A detached garage would have the pediment facing S Park ST. 2 overhead garage doors are planned, 10' wide x 9' high, facing S Park ST. The width and height of the garage was determined after discussing clearances with a door installation company. The height to the peak of the garage is designed at 18' 4". Mr. Varner is working with Ellis Brothers Concrete to have poured walls done with a brick imprint on the outside. The home is brick. The poured wall with brick imprint will be painted to match the house.

Mr. Dzik asked if the garage door design had been determined.

Mr. Varner provided two options; one with 20 panels, the other appearing more like a barn door that coordinates with the walk-in door to the right of the bay window in the carriage house/family room. Either door is acceptable to him.

Mr. Dzik asked if he has decided on color for the doors. Mr. Varner said the house trim is white and the brick

is painted eggshell, an off-white. There is a noticeable contrast. He thinks that would be appropriate for the doors. The door to the right of the bay window is painted white. The trim around the bay window is painted white.

Mr. Broeren asked about the curb cut in front of the existing carriage house/family room and if it would be removed. Mr. Varner would like the curb cut removed, once the proposed garage is built.

Mr. Drews confirmed that Mr. Varner’s preferred design is the detached garage. He wants to save the plantings at the end of the existing home. The Board of Zoning Appeals will determine whether the garage will be detached or attached.

Mr. Dzik outlined the options - to approve one design or the other or both for Historical District impact, then the Board of Zoning Appeals will determine the allowed setbacks.

Mr. Broeren asked if the garage door designs shown, different between the primary design and the secondary design, are set for each design location - detached or attached. Mr. Varner said either design could be used with either site location.

Mike Hillier (sworn in) - asked what BZA will be deciding on.

Development Services Manager, Lacie Blankenhorn, explained the variances being requested based on each design - detached vs attached. The detached design proposes a zero lot line setback on Park ST and a 2’ setback off the rear property line. The overall height will require a variances as well, as the maximum height allowed by Code is 18’. If BZA is not willing to grant the 2’ rear property line setback, then the secondary design requests a zero lot line setback along Park ST to stay in line with the existing structure. The standard setback for a detached garage is 5’.

Correspondence submitted via the Development Services Manager: Peter Boutin, residing at 400 E Gambier ST left a voicemail stating he is in total support of this proposed construction.

Mr. Dzik asked if there was a motion to approve the application. Mr. Hawkins said so moved.

Mr. Broeren said clarification was needed since there were at least 2 options presented.

Does the HRC wish to approve both designs? And do they want to specify the type of garage doors to be used with 1 or both designs.

Mr. Hawkins said he was ok with the primary design, preferring not to approve both.

There was no second to the motion.

Mr. Drews made a motion to approve either design and leave the garage door selection to either presented.

Ms. Poland seconded the motion.

Discussion: Mr. Dzik voiced his support of the motion. He also understands Mr. Hawkins’ position. Mr. Dzik thinks it’s best to leave all options without objections for Mr. Varner to take to the BZA and not have to return to the HRC. He is comfortable with Mr. Varner’s descriptions that the proposed garage will preserve the character of the neighborhood.

Mr. Swallow said he would be more comfortable if there were a final approval, maybe administratively, before the build goes forward.

Mr. Dzik asked to amend the motion to include a final Administrative Review, following BZA approval and prior to the Zoning Permit being issued. Mr. Varner should submit final details of the garage doors. Mr. Swallow seconded the amendment. Voting: AIF of the amendment.

RESULT:	ACCEPT AS MODIFIED [UNANIMOUS]
MOVER:	Robert Drews, Member
SECONDER:	Sibley Poland, Member
AYES:	Swallow, Drews, Dzik, Hawkins, Poland, Filkins
EXCUSED:	Starr, Ulery, Diehl

- Motion to amend motion, include final Administrative Review by submitting final details of garage doors

RESULT:	ADOPTED [UNANIMOUS]
MOVER:	Richard Dzik, Safety-Service Director
SECONDER:	Austin Swallow, Member
AYES:	Swallow, Drews, Dzik, Hawkins, Poland, Filkins
EXCUSED:	Starr, Ulery, Diehl

ADJOURNMENT

- Adjourn Motion

Mr. Swallow made a motion to adjourn the meeting, Mrs. Filkins seconded and the meeting was adjourned at 4:39PM.



Historical Review Commission
40 Public Square
Mount Vernon, OH 43050

Meeting: 06/10/21 4:00 PM
 Dept: **Historical Review Commission**

SCHEDULED

Category: N/A
 Prepared By: Lacie Blankenhorn
 Initiator: Lacie Blankenhorn

HRC-ITEM NUMBER (ID # 2339)

DOC ID: 2339

2021-HRC-16 : 111 HIGH ST COURTHOUSE ACCESSIBLE ENTRY & ANNEX BUILDING RENOVATIONS

The Knox County Commissioners seek to add an accessible entry to the main courthouse, upgrade sidewalks and landscaping. Additionally, they seek to renovate the courthouse's annex building with new paint, a new roof, and new doors and windows.

COMMENTS - Current Meeting:

Development Services Manager, Lacie Blankenhorn introduced the first case. 2021-HRC-16 - 111 E High ST - Courthouse Accessible Entry & Annex Building Renovations: The Knox County Commissioners seek to add an accessible entry to the main courthouse, and upgrade sidewalks and landscaping. Additionally, they seek to renovate the courthouse's annex building with new paint, a new roof (like kind), and new doors and windows.

Greg Lonergan (sworn in) - reviewed with the Commission the presentation that was submitted with the application showing the proposed roofing, windows, and doors for the annex building. The vinyl windows will be replaced with aluminum covered wood windows. The center doorway is proposed to be removed and replaced with a window. They don't think the door was original. The sign post will be removed. A window infill example on the opposite side was shown. The County has brick that they think will match exactly. The doors will be replaced with Pella wood doors. Landscaping will be placed in front of the gas meter. The annex entry does not meet ADA. The slab will be raised to remove the existing step and make it ADA accessible. A tree will be removed, as they feel it is too close to the building foundation. The sidewalk arrangement will be aligned for a more direct route.

The current accessible entrance to the courthouse is through a basement entrance off of the alley on the West side, past the dumpster. The path is not ideal or appropriate and not used for the general public. The request is to convert the Southern most window on the East side of courthouse to a door with an accessible ramp. Some bushes will be removed. The wall below the window will be removed to accommodate the opening for the ramp. Handicap parking is adjacent to the proposed entrance. This entrance will allow for all to pass through the standard security checkpoint. The middle of the ramp will accommodate landscaping. Details of the windows, doors, and hardware was provided in the application packet.

There was no one else present to contribute, nor was there any written or verbal communication about the request through the Development Services Manager.

Mr. Dzik added, it looks like they are doing a lot of improvements to maintain what exists or to bring back some historic features.

Mr. Broeren said he has spent some time in the annex. The windows were very drafty.

RESULT:	ACCEPT [UNANIMOUS]
MOVER:	Austin Swallow, Member
SECONDER:	Lacey Filkins, Member
AYES:	Swallow, Drews, Dzik, Hawkins, Poland, Filkins
EXCUSED:	Matthew T. Starr, Jeffrey Scott Ulery, Eric Diehl



City of Mount Vernon, Ohio
Historic Review Commission

Application for Certificate of Appropriateness

Applicant:

Name: Joshua Tamey - MKC Architects (ON BEHALF OF THE KNOX Co. Commissioners)
Address: 161 N 4th Street, Columbus OH 43215
Telephone: (614) 689-9552 Fax: N/A.

Site Information:

Address: 111 High Street Mount Vernon OH 43050
Legal Description: OP 9-10-11-12 / Courthouse
Parcel Number: 66-50176.000 Deed Volume and Page: Deeded Acres = 0
Legal Acres = 0.8
Zoning District: P-1, Public District
Owner: Commissioners Knox Co
Address: 117 E High St., Mt. Vernon OH 43050

Project Description: We are seeking to renovate the courthouse's annex building inc. new paint, a new roof, and new doors/windows on the exterior. Additionally, we seek to add an accessible entry to the main courthouse. Finally, we will upgrade sidewalks & landscaping.

Site plans, building elevations, renderings, and any other drawings, as well as the detailed narrative statements must be attached to this application. Please see attached addendum.

A deposit of \$50.00 is required to be submitted at the time of filing. Applicant will be billed for any costs which exceed the deposit.

Applicant hereby certifies that the information submitted on this application and on any sketches, drawings or other documents required to be submitted with the application are true and exact.

Signature of Applicant: Joshua Tamey Date: 05/19/21

FOR OFFICIAL USE ONLY

Case No.: _____

Knox County Courthouse & Annex Improvements

Mount Vernon, Ohio | May 19, 2021



MKC | ARCHITECTS

BUILDING 1 - KNOX COUNTY COURTHOUSE ANNEX



The existing building, while generally quite nice, has not been in use for many years. The proposed renovation will take care of deferred maintenance and bring the property again into active use as an additional courtroom.

EXISTING CHALLENGES



inappropriate replacement doors - painted transoms



inappropriate vinyl replacement windows



two-toned, street facing gas meter



entries do not meet ADA



overgrown landscaping and unused signpost

Attachment: 21-020_2021.05.19_Historic Review Addendum (2339 : 2021-Hrc-16)

BUILDING 1 - KNOX COUNTY COURTHOUSE ANNEX
PROPOSED RENOVATIONS



Infill middle door with a window to allow for courtroom security

Replace metal roof in kind. No changes to appearance.

Re-paint all mouldings and trim. No color changes.

Replace existing vinyl windows with Pella Aluminum Clad Wood Windows. Single hung and white coloring will remain. All windows.

Replace doors with Pella Wood Doors. Half Lite.

Replace glass in transoms above with new glass.



Another door has been replaced with a door on the alley side long ago and infilled with brick below.

Attachment: 21-020_2021.05.19_Historic Review Addendum (2339 : 2021-Hrc-16)

BUILDING 1 - KNOX COUNTY COURTHOUSE ANNEX

MOCK-UP

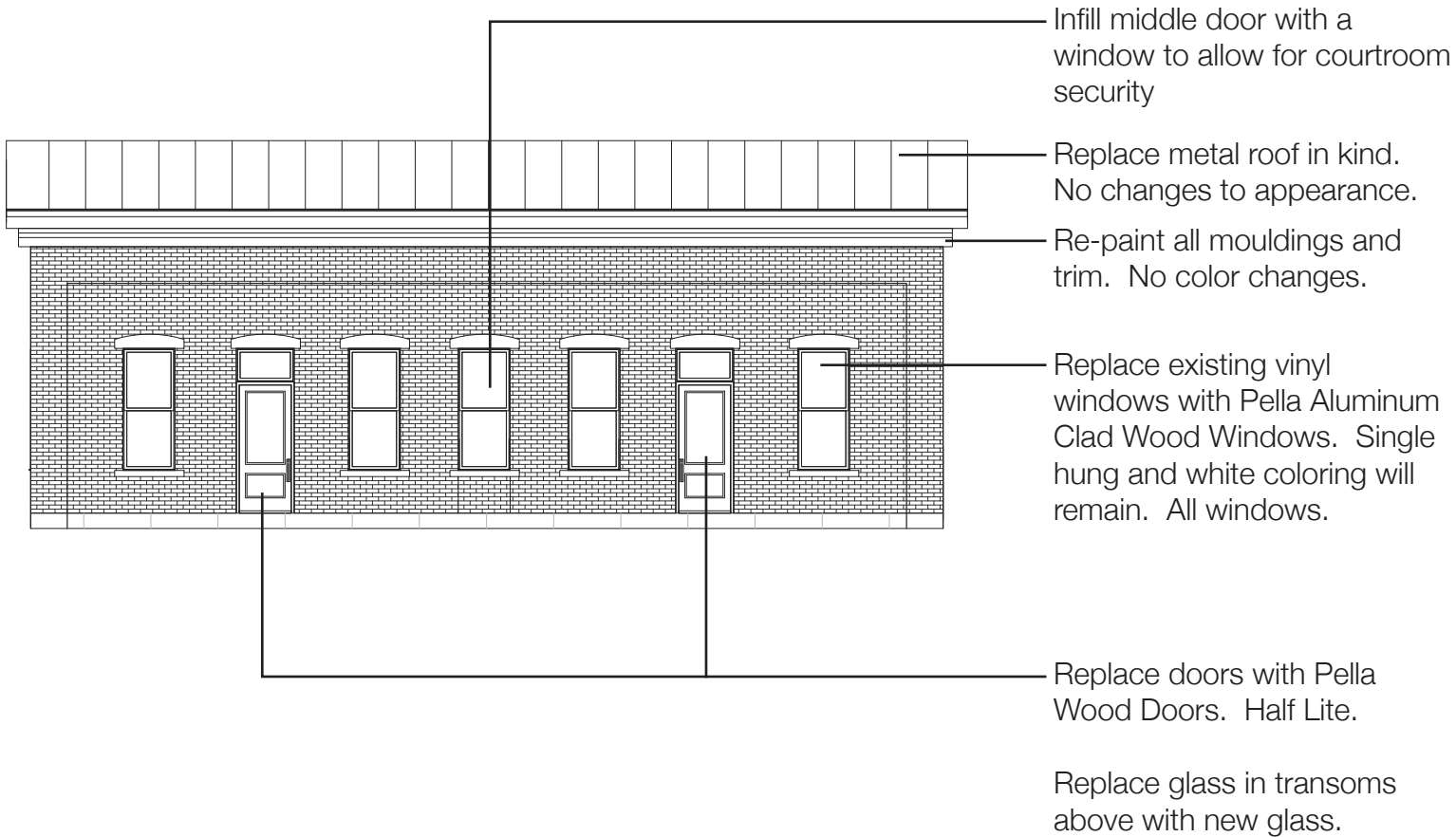

Another door has been replaced with a door on the alley side long ago and infilled with brick below.

Attachment: 21-020_2021.05.19_Historic Review Addendum (2339 : 2021-Hrc-16)

SITE IMPROVEMENTS - KNOX COUNTY COURTHOUSE ANNEX
CURRENT



unsightly gas meter



does not meet ADA



unused sign post



scrub tree too close to building foundation



current sidewalks do not directly lead to annex - unclear if it is public

Attachment: 21-020_2021.05.19_Historic Review Addendum (2339 : 2021-Hrc-16)

SITE IMPROVEMENTS - KNOX COUNTY COURTHOUSE ANNEX
PROPOSED

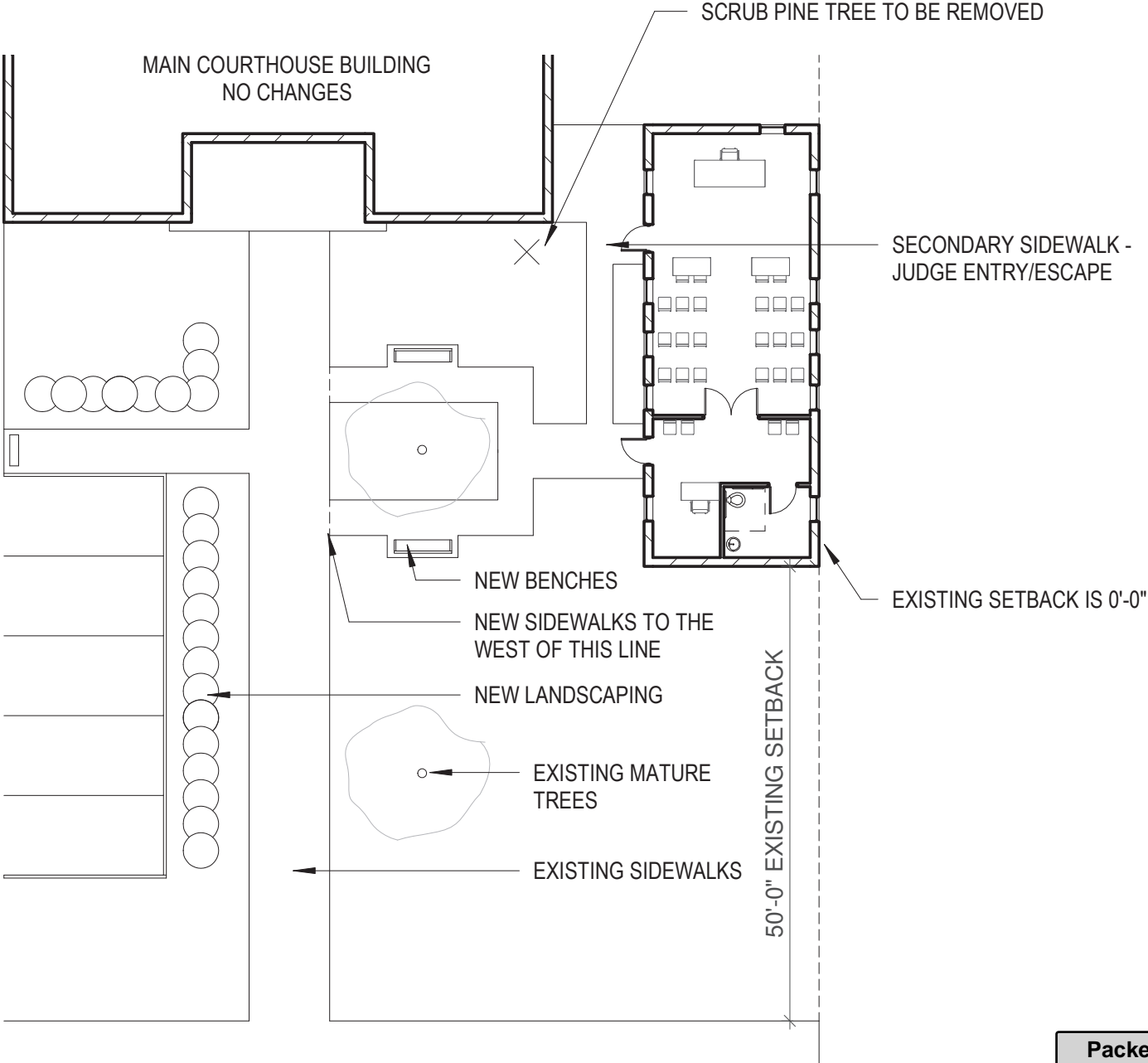

Attachment: 21-020_2021.05.19_Historic Review Addendum (2339 : 2021-Hrc-16)

ACCESSIBLE ENTRY - KNOX COUNTY COURTHOUSE ANNEX
CURRENT



The main security checkpoint is at the front of the building off of High Street. The goal is for all patrons to enter at the same location, as codified by ADA.



Due to the historic nature of both the front and rear facade, adding a ramp to either would be inauthentic and unwise. A ramp that enters from the side and adjoins the security checkpoint is the best way forward.

Currently, the only accessible entry to the courthouse is off of the alleyway. Patrons enter through a mechanical basement, past hvac equipment and a dumpster. They must then ring a doorbell and wait for a security guard to leave their post and escort them through the building to be checked in at security.

Attachment: 21-020_2021.05.19_Historic Review Addendum (2339 : 2021-Hrc-16)

SITE IMPROVEMENTS - KNOX COUNTY COURTHOUSE ANNEX
PROPOSED

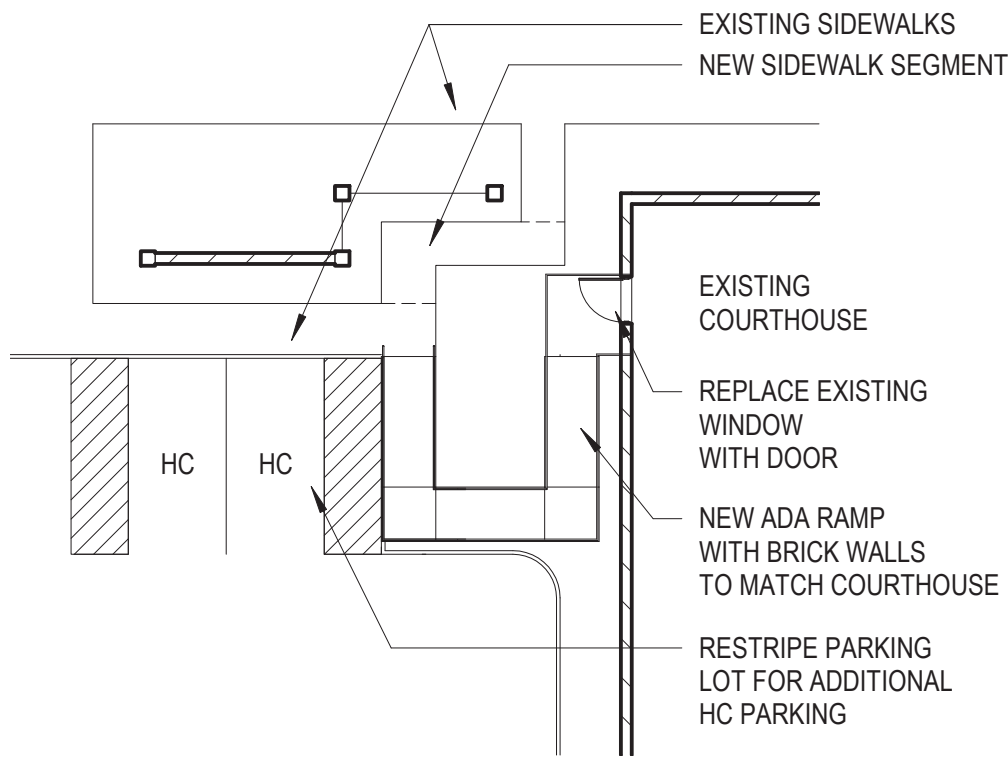

window proposed to become door



*window proposed to become door
Street View*



ramp to be constructed of matching brick with concrete cap and black metal railings

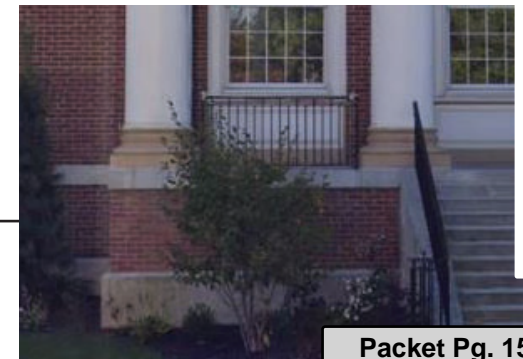

Attachment: 21-020_2021.05.19_Historic Review Addendum (2339 : 2021-Hrc-16)



Pella® Reserve™

Traditional Wood & Clad/Wood

Exquisitely designed windows and doors with unparalleled historical detailing.

Double-Hung Interior



Double-Hung Exterior



- **Historical details**

Our most historically authentic line of wood windows and patio doors. Featuring through-stile construction, deliberate proportions and intricate profiles. Pella Reserve - Traditional products are the ideal choice for historical renovations and traditional building projects.

- **Authentic hardware**

Complement your project with historically authentic spoon-lock window hardware. Our Antiek casement window hardware is inspired by period furniture to deliver authentic traditional style.

- **Architectural interest**

Featuring the industry's only foam spacer solution, Pella's Integral Light Technology® grille helps capture the look of true-divided-light without sacrificing energy performance. Further your aesthetic with the putty profile, recreated with historically accurate angles – providing meaningful depth and a realistic shadow. Pella Reserve products offer the industry's deepest sash dimension.

- **Virtually unlimited customization**

If you can dream it, we can build it with our most customizable product line. From extra tall to extra wide, Pella can craft unique windows that complement your aesthetic. Custom sizes, grille patterns and designs, finishes, wood types and glass options are available.

- **Tailor-made solutions**

From preliminary drawings to installation, Pella's expert team of architects, engineers, drafters and consultants can work to deliver custom window and door solutions for your project. Partner with Pella to achieve your unique vision without concessions.

- **Intentional innovation**

Winner of the 2019 Most Innovative Window from Window and Door Magazine, the Integrated Rolscreen® retractable screen preserves aesthetic view. It is a double- and single-hung screen that appears when you open the window, and rolls away, out of sight, when you close it.

- **Durable interiors and extruded aluminum exteriors**

To help save you time on the jobsite, interior finish options are available in four paints, eleven stains and primed and ready-to-paint. To complement your exterior aesthetic, choose from our carefully curated color palette or define your own custom color for your project.

- **ENERGY STAR® certified¹**

Pella wood products offer energy-efficient options that will meet or exceed ENERGY STAR guidelines in all 50 states. Pella Reserve products with triple-pane glass have been awarded the ENERGY STAR Most Efficient Mark in 2021.¹

- **Testing beyond requirements**

At Pella, our products are tested beyond requirements to help ensure they have long-lasting performance and reduce call-backs for you.

- **Best limited lifetime warranty²**

Pella Reserve products are covered by the best limited lifetime warranty in the business for wood windows and patio doors.²

Available in these window and patio door styles:



Special shape windows also available.

Product Specifications

Window & Patio Door Styles	Min. Width	Min. Height	Max. Width	Max. Height	Performance Class & Grade	Performance Values			Frame / Install
						U-Factor	SHGC	STC	
Awning	13-3/4"	13-3/4"	59"	59"	LC40-CW50	0.25-0.29	0.18-0.47	27-35	Fold-out Fin, Block Frame, EnduraClad Exterior Trim / Brickmould
Precision Fit Awning	17"	17"	53"	29"	R45-CW50	0.28-0.32	0.18-0.47	27-30	Pocket Replacement
Casement	13-3/4"	13-3/4"	47"	108"	R35-CW50	0.25-0.29	0.18-0.47	27-34	Fold-out Fin, Block Frame, EnduraClad Exterior Trim / Brickmould
Precision Fit Casement	17"	17"	35"	73"	R35-CW50	0.28-0.33	0.18-0.47	27-30	Pocket Replacement
Fixed Casement	10"	10"	144"	144"	R35-CW50	0.25-0.29	0.18-0.47	27-35	Fold-out Fin, Block Frame, EnduraClad Exterior Trim / Brickmould
Precision Fit Fixed Casement	17"	17"	59"	73"	R45-CW50	0.28-0.33	0.18-0.47	27-30	Pocket Replacement
Double-Hung	14"	24-3/8"	48"	96"	CW30-CW50	0.25-0.30	0.19-0.53	28-35	Fold-out Fin, Block Frame, EnduraClad Exterior Trim / Brickmould
Precision Fit Double-Hung	13-1/2"	23-3/4"	48"	84"	CW40-CW50	0.25-0.31	0.19-0.53	26-30	Pocket Replacement
Monumental Hung	13-3/4"	24"	72"	144"	LC25-CW50	0.25-0.30	0.17-0.47	29-34	Fold-out Fin, Block Frame, EnduraClad Exterior Trim / Brickmould
In-Swing Hinged Patio Door (Single)	18"	36"	48"	199-1/2"	LC40-LC55	0.25-0.29	0.14-0.40	31-35	
In-Swing Hinged Patio Door (Double)	36"	36"	96"	119-1/2"	LC40-LC55	0.25-0.29	0.14-0.40	31-35	
Out-Swing Hinged Patio Door (Single)	18"	36"	48"	119-1/2"	R50-LC70	0.25-0.30	0.14-0.39	30-36	
Out-Swing Hinged Patio Door (Double)	36"	36"	96"	119-1/2"	R50-LC70	0.25-0.30	0.14-0.39	30-36	
Sliding Patio Door (O)	30-3/4"	74"	60-3/4"	119-1/2"	LC40-LC70	0.29-0.32	0.15-0.42	-	
Sliding Patio Door (OX, XO)	59-1/4"	74"	119-1/2"	119-1/2"	LC35-LC65	0.29-0.32	0.15-0.42	29-35	
Sliding Patio Door (OXO)	90"	74"	180"	119-1/2"	LC30-LC45	0.29-0.32	0.15-0.42	-	
Sliding Patio Door (OXXO)	116-1/8"	74"	236-1/8"	119-1/2"	LC25-LC40	0.29-0.32	0.15-0.42	-	
Multi-Slide Patio Door	40-1/4"	50-1/2"	701-5/8"	119-1/2"	R15-LC25 ³	0.30 - 0.36	0.15 - 0.46	31	
Bifold Patio Door	31-3/4"	55-1/2"	312"	119-1/2"	R15-LC25 ³	0.26-0.44	0.13-0.45	-	

Window sizes available in 1/8" increments

Special sizes available. For more information regarding performance, visit pella.com/performance. For more information regarding frame and installation types, visit PellaADM.com.

Grilles

Integral Light Technology[®]

Choose the look of true divided light featuring the industry's only foam spacer.

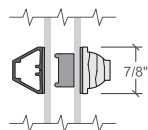

Putty Glaze Exterior with Ogee Interior⁴
7/8", 1-1/4" or 2"

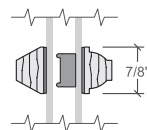

Putty Glaze Exterior with Ogee Interior⁴
7/8", 1-1/4" or 2"

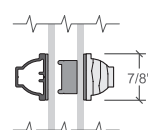

Ogee Exterior with Ogee Interior⁴
7/8", 1-1/4" or 2"

Cross Sections

Cross Sections

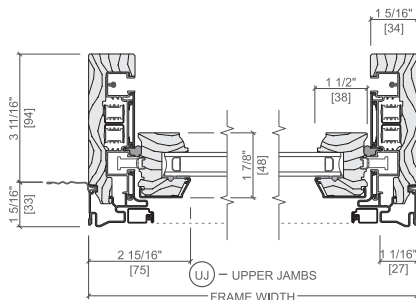

Optional Fold-out Installation Fin

The double-hung cross sections provide visual reference to the historic putty exterior profile and traditional, beveled Ogee interior that add architectural interest to your project.

Attachment: 21-020_2021.05.19_Historic Review Addendum (2339 : 2021-Hrc-16)

Window Hardware

Classic Collection

Get a timeless look with authentic styles in classic finishes.



Fold-away Crank
Antiek



Spoon-Style Lock

Finishes:



Champagne

White

Brown

Matte Black



Oil-Rubbed Bronze



Satin Nickel



Satin Brass⁵

Rustic Collection

Create a distinct and charming look with distressed finishes.



Fold-away Crank
Antiek



Spoon-Style Lock

Finishes:



Distressed Bronze

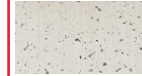

Distressed Nickel

Essential Collection

Select from popular designs and finishes to suit every style.



Fold-away Crank



Cam-Action Lock

Finishes:



Champagne

White

Brown

Matte Black



Oil-Rubbed Bronze

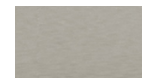

Satin Nickel



Satin Brass⁵

Patio Door Hardware

Classic Collection

Choose timeless pieces, created in collaboration with Baldwin® Hardware, for a look that will never go out of style.

BALDWIN



Hinged & Bifold Patio Door Handle
Virago



Sliding & Multi-Slide Patio Door Handle
Ambrose



Multi-Slide Patio Door Handle^{6,7}

Finishes:



Matte Black

Oil-Rubbed Bronze

Satin Nickel

Satin Brass⁵

Essential Collection

Elevate your style and transform a home with elegant selections.



Hinged & Bifold Patio Door Handle



Sliding Patio Door Handle



Multi-Slide Patio Door Handle^{6,7}

Finishes:



Champagne

White

Brown

Matte Black



Oil-Rubbed Bronze

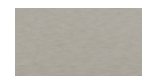

Satin Nickel



Satin Brass⁵

Colors

Wood Types

Choose the wood species that best complements your project's interior.



Prefinished Pine Interior Colors

Custom interior finishes, unfinished or primed and ready-to-paint are also available.

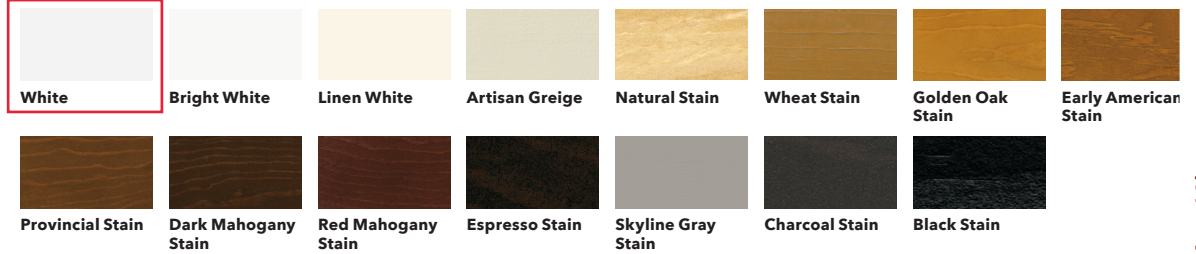

Extruded Aluminum-Clad Exterior Colors

Our low-maintenance EnduraClad® exterior finish resists fading. Take durability one step further with EnduraClad Plus which also resists chalking and corrosion.⁸



Custom colors are also available.

Added Peace of Mind

Integrated Security Sensors

Integrated wireless security sensors maintain aesthetics, streamline security installation and ensure no warranty loss is caused by post-installation drilling. Sensors can be monitored via the free Pella® Insynctive® App and are compatible with major security panel systems.⁹ For more information, go to connectpella.com.



The Best Limited Lifetime Warranty in the Industry

We know your reputation matters and you stake your reputation on quality, dependable products. That's why we have the best limited lifetime warranty in the industry for wood windows and patio doors.²

¹ Some Pella products may not meet ENERGY STAR® guidelines in Canada. For more information, contact your local Pella sales representative or go to energystar.gc.ca.
² Based on comparing written limited warranties of leading national wood window and wood patio door brands. See written limited warranty for details, including exceptions and limitations, at pella.com/warranty or contact Pella Customer Service.
³ Ratings are contingent on product configurations.
⁴ Color-matched to your product's interior and exterior color.
⁵ Available Fall 2021.
⁶ Flush multi-slide handle is a Pella exclusive design.
⁷ Flush multi-slide handle is not available in Champagne.
⁸ EnduraClad Plus protective finish is not available with all colors. See your local Pella sales representative for availability.
⁹ Requires the Insynctive App on a smart device, an Insynctive Bridge and a wireless home router with internet connection.



Classic Collection

Pella's Classic Collection adds historical charm and elegance to your projects. With true-divided-light grilles and beveled glass, these doors complement other classic features in customers' homes – such as windows with decorative glass and artistic woodwork. Pella's Classic Collection is the choice for builders who desire authenticity down to the finest detail.

Mahogany*



2 Panel
3/4 Light
30" x 96"
32" x 96"
36" x 96"



2 Panel 3/4 Light
36" x 80"
36" x 96"



2 Panel 3/4 Light
30" x 80"
32" x 80"
36" x 80"



2 Panel 3/4 Light
30" x 80"
32" x 80"
36" x 80"



2 Panel 3/4 Light
30" x 96"
32" x 96"
36" x 96"



2 Panel
Continuous Arch 1
60" x 96"
64" x 96"
72" x 96"



2 Panel
Continuous Arch 1
60" x 96"
64" x 96"
72" x 96"



2 Panel
Continuous Arch 2
60" x 96"
64" x 96"
72" x 96"

* Glass patterns may change based on size and options chosen. Refer to the full catalog for details on Pella's complete line of wood entry doors.
(1) Available as rectangular top frame.
(2) Available as an arch top frame.

Attachment: 21-020_2021.05.19_Historic Review Addendum (2339 : 2021-Hrc-16)



Features and Options

Pella® wood entry doors feature a floating panel that allows the door to contract and expand to outside weather extremes – helping protect it from splitting or cracking.



Multipoint Lock Multipoint Hardware Options

Pella’s entry door systems not only look beautiful; they perform beautifully too. With just one twist of the thumbturn, the optional multipoint lock system secures the door at the top, middle and bottom – for superior durability, performance and added security.



Exterior Handles



Finishes

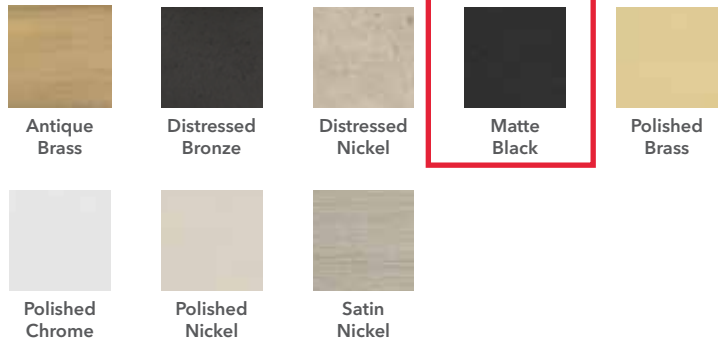

Finishes vary based on handle style.

Standard Hardware Options

Handle Sets

<p>Standard:</p> <p>Satin Nickel, Bright Brass, and Oil-Rubbed Bronze</p>	<p>Chesapeake / Del Mar:</p> <p>Bright Brass, Antique Brass, Satin Nickel, Oil-Rubbed Bronze, Matte Black</p>	<p>Santa Cruz / Seattle:</p> <p>Satin Nickel, Polished Nickel, Polished Chrome, Matte Black</p>	<p>Longview / Elkhorn:</p> <p>Distressed Nickel and Distressed Bronze</p>
---	---	---	---

Attachment: 21-020_2021.05.19_Historic Review Addendum (2339 : 2021-Hrc-16)



Features and Options



Rustic Walnut and Mahogany woods are available to perfectly complement the flooring, cabinetry and furniture of your customers' homes. Delicate graining, bold beauty marks and rich color variations highlight the unique qualities of each wood type.

Rustic Walnut Options

Decorative Accents

Cross Buck



*with and without clasps

Clavos



Square, Diamond or Round Clavos

Hingestraps



20" and 14" Straps
(20" hinge straps come on 42" or 84" doors only.)

Speakeasy Grille



Speakeasy Door



Square

Eye-brow



Roundtop

Hinge options Sill Options



Bright Brass



Satin Nickel



Black



Oil-Rubbed Bronze

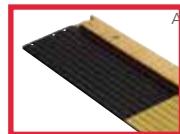

Anodized Bronze

Anodized Brass

Aluminum Mill



Standard Sill In-Swing



ADA (Handicap) Sill



Standard Sill Out-Swing



Wood Sill - Mahogany or Oak

Stain Colors

	Chapparral	Saddle	Chappo	Rawhide	Rosewood	Bordeaux	Charcoal	Graphite	Natural
Rustic Walnut									
Mahogany									

Attachment: 21-020_2021.05.19_Historic Review Addendum (2339 : 2021-Hrc-16)



Sizes and Options - Transoms

Rectangle

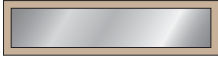

		36" Single Door	12"-36"-12" Door with Sidelights	12-5/8"-36"-12-5/8" Door with Sidelights	14"-36"-14" Door with Sidelights	36"-36" Double Door
		3' 1-11/16" X 1' 3-9/16"	5' 4-13/16" X 1' 3-9/16"	5' 6-1/16" X 1' 3-9/16"	5' 8-13/16" X 1' 3-9/16"	6' 2-3/8" X 1' 3-9/16"
Wood Type	Mahogany	•	•	•	•	•
	Rustic Walnut		•		•	•
Moulding	None	•	•	•	•	•
	Raised		•		•	•
Clear Glass	No Bevel	•		•	•	•
	Bevel	•	•	•	•	•
Obscure Glass	Satin				•	•
	Flemish			•	•	•
	Rain	•				
	Reeded				•	•
Decorative Glass	Arcadia			•	•	•
	Bonnabel			•	•	•
	Diamond Bevel					
	Menger			•	•	•
	Queen Anne		•		•	•
	Sarasota			•	•	•
	Serenade			•	•	•
	Sonnet			•	•	•
Symphony			•	•	•	
True Divided Light	Cottage					
	Prairie		•		•	•
	Traditional	•	•		•	•
	Top Row					

Attachment: 21-020_2021.05.19_Historic Review Addendum (2339 : 2021-Hrc-16)



Historical Review Commission
40 Public Square
Mount Vernon, OH 43050

Meeting: 06/10/21 4:00 PM
Dept: Historical Review Commission

SCHEDULED

Category: N/A
Prepared By: Lacie Blankenhorn
Initiator: Lacie Blankenhorn

HRC-ITEM NUMBER (ID # 2340)

DOC ID: 2340

2021-HRC-14 : 306 E GAMBIER ST - GARAGE

Mr. Varner seeks a Certificate of Appropriateness to construct a 26' wide x 24' deep garage.

His primary design has the pediment of the roof facing East/West toward South Park ST. A variance is being requested from the Board of Zoning Appeals to determine the exact location of the garage on the property which will determine the location of the pediment either East/West or South/attached to the home.

See accompanying documents for further details.

COMMENTS - Current Meeting:

Development Services Manager, Lacie Blankenhorn introduced the second case. 2021-HRC-14 - 306 E Gambier ST - a garage: Mr. Varner seeks a Certificate of Appropriateness to construct a 26' wide x 24' deep garage. His primary design has the pediment of the roof facing East/West toward South Park ST. A variance is being requested from the Board of Zoning Appeals to determine the exact location of the garage on the property which will determine the location of the pediment either East/West or South and attached to the home. See accompanying documents for further details.

Stacey Varner (sworn in) - explained he purchased the home in October of last year. He contacted Lacie prior to the purchase to research if a garage could be built. She explained the processes to him. There is a nice flowering tree and mature flowering rose bush at the Southwest corner of the house that he would like to keep. Both plants would have to be destroyed to attach the garage. By detaching the garage and placing it 2' from the rear property line and along the Park ST property line, in line with the existing home, the plants can be saved. A detached garage would have the pediment facing S Park ST. 2 overhead garage doors are planned, 10' wide x 9' high, facing S Park ST. The width and height of the garage was determined after discussing clearances with a door installation company. The height to the peak of the garage is designed at 18' 4". Mr. Varner is working with Ellis Brothers Concrete to have poured walls done with a brick imprint on the outside. The home is brick. The poured wall with brick imprint will be painted to match the house.

Mr. Dzik asked if the garage door design had been determined.

Mr. Varner provided two options; one with 20 panels, the other appearing more like a barn door that coordinates with the walk-in door to the right of the bay window in the carriage house/family room. Either door is acceptable to him.

Mr. Dzik asked if he has decided on color for the doors. Mr. Varner said the house trim is white and the brick is painted eggshell, an off-white. There is a noticeable contrast. He thinks that would be appropriate for the doors. The door to the right of the bay window is painted white. The trim around the bay window is painted white.

Mr. Broeren asked about the curb cut in front of the existing carriage house/family room and if it would be removed. Mr. Varner would like the curb cut removed, once the proposed garage is built.

Mr. Drews confirmed that Mr. Varner's preferred design is the detached garage. He wants to save the plantings at the end of the existing home. The Board of Zoning Appeals will determine whether the garage will be detached or attached.

Mr. Dzik outlined the options - to approve one design or the other or both for Historical District impact, then the Board of Zoning Appeals will determine the allowed setbacks.

Mr. Broeren asked if the garage door designs shown, different between the primary design and the secondary design, are set for each design location - detached or attached. Mr. Varner said either design could be used with either site location.

Mike Hillier (sworn in) - asked what BZA will be deciding on.

Development Services Manager, Lacie Blankenhorn, explained the variances being requested based on each design - detached vs attached. The detached design proposes a zero lot line setback on Park ST and a 2' setback off the rear property line. The overall height will require a variances as well, as the maximum height allowed by Code is 18'. If BZA is not willing to grant the 2' rear property line setback, then the secondary design requests a zero lot line setback along Park ST to stay in line with the existing structure. The standard setback for a detached garage is 5'.

Correspondence submitted via the Development Services Manager: Peter Boutin, residing at 400 E Gambier ST left a voicemail stating he is in total support of this proposed construction.

Mr. Dzik asked if there was a motion to approve the application. Mr. Hawkins said so moved.

Mr. Broeren said clarification was needed since there were at least 2 options presented.

Does the HRC wish to approve both designs? And do they want to specify the type of garage doors to be used with 1 or both designs.

Mr. Hawkins said he was ok with the primary design, preferring not to approve both.

There was no second to the motion.

Mr. Drews made a motion to approve either design and leave the garage door selection to either presented. Ms. Poland seconded the motion.

Discussion: Mr. Dzik voiced his support of the motion. He also understands Mr. Hawkins' position. Mr. Dzik thinks it's best to leave all options without objections for Mr. Varner to take to the BZA and not have to return to the HRC. He is comfortable with Mr. Varner's descriptions that the proposed garage will preserve the character of the neighborhood.

Mr. Swallow said he would be more comfortable if there were a final approval, maybe administratively, before the build goes forward.

Mr. Dzik asked to amend the motion to include a final Administrative Review, following BZA approval and prior to the Zoning Permit being issued. Mr. Varner should submit final details of the garage doors. Mr. Swallow seconded the amendment. Voting: AIF of the amendment.

RESULT:	ACCEPT AS MODIFIED [UNANIMOUS]
MOVER:	Robert Drews, Member
SECONDER:	Sibley Poland, Member
AYES:	Swallow, Drews, Dzik, Hawkins, Poland, Filkins
EXCUSED:	Matthew T. Starr, Jeffrey Scott Ulery, Eric Diehl



City of Mount Vernon, Ohio
Historic Review Commission

Mount Vernon Application for Certificate of Appropriateness

Applicant:

Name: Mr. Stacey Varner
Address: 306 East Gambier Street
Telephone: 425-444-1332 Fax: _____

Site Information:

Address: 306 East Gambier Street Mount Vernon, OHIO 43050
Legal Description: Thomas 467
Parcel Number: 66-03347.000 Deed Volume and Page: _____
Zoning District: _____
Owner: Mr. Stacey Varner
Address: 306 East Gambier Street Mount Vernon, OHIO 43050

Project Description: Garage Construction:

- a) Size: 26' wide X 24' deep; (width is 2 feet greater than PRIMARY design files reference to accommodate car door openings and moving large equipment thru the garage to west side of garage in the event of some type of digging or ground/foundation repair work that may be needed in the future (placing a garage door on WEST side of garage to facilitate moving large equipment into yard in the event needed. b) Doors: 2 – 10' wide X 9' tall; c) Please reference Elevation view and Site Plan in files named: 2021-05-25 21v15 VarnerGarage Elevation Primary and 2021-05-24 21v15 VarnerGarage SitePlan Primary; d) Pediment of roof would face East/West toward South Park Street; e) Entrance from South Park Street; f) Materials: in the process of gathering estimates for 2 material designs: 1) Concrete poured walls with external brick imprints to be painted matching color of existing house structure; 2) Wood clapboard siding to be painted matching color of existing house structure. See elevation view referenced earlier for garage doors and windows. g) Additional Attachments: Site Plan (Secondary), Elevation (Secondary), Survey, and Location Survey. h) Secondary design (provided pending decision from Zoning Board for locating garage at 2-foot distance from South property line).

Site plans, building elevations, renderings, and any other drawings, as well as the detailed narrative statements must be attached to this application. Nine (9) sets of these documents are required to be submitted with the application.

A deposit of \$50.00 is required to be submitted at the time of filing. Applicant will be billed for any costs which exceed the deposit.

Applicant hereby certifies that the information submitted on this application and on any sketches, drawings or other documents required to be submitted with the application are true and exact.

Stacey Varner
Signature of Applicant

June 1, 2021
Date

FOR OFFICIAL USE ONLY

Case No.: _____



Attachment: 2021-05-25_21v15_VarnerGarage_Elevation_Primary (2340 : 2021-Hrc-14)

SOUTH PARK STREET ELEVATION

1/8" = 1'-0"

VARNER GARAGE

MT. VERNON, OH

MAY 25, 2021

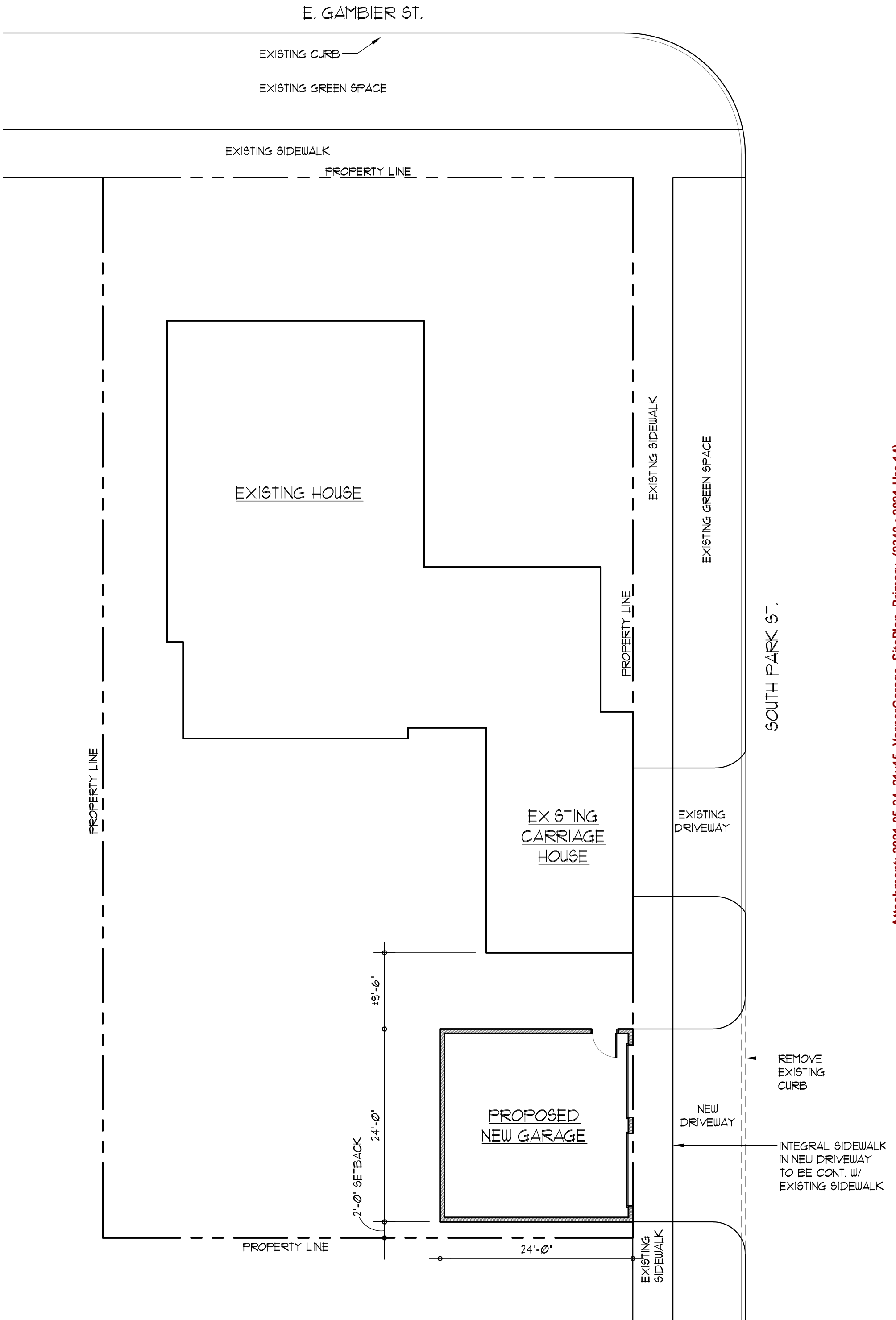

Attachment: 2021-05-24_21v15_VarnerGarage_SitePlan_Primary (2340 : 2021-Hrc-14)

SITE PLAN

3/32" = 1'-0"

VARNER GARAGE

MT. VERNON, OH

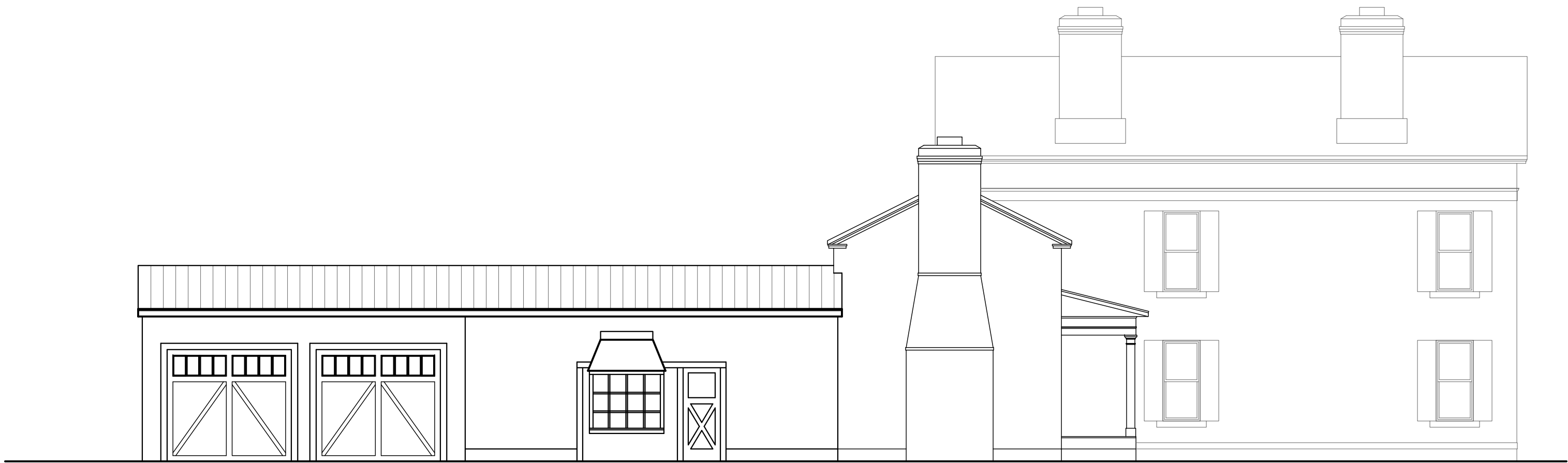

Attachment: 2021-06-02_21v15_VarnerGarage_Elevation_Secondary (2340 : 2021-Hrc-14)

SOUTH PARK STREET ELEVATION

1/8" = 1'-0"

VARNER GARAGE

MT. VERNON, OH

JUNE 2, 2021

E. GAMBIER ST.

EXISTING CURB

EXISTING GREEN SPACE

EXISTING SIDEWALK

PROPERTY LINE

EXISTING HOUSE

EXISTING SIDEWALK

EXISTING GREEN SPACE

PROPERTY LINE

EXISTING CARRIAGE HOUSE

EXISTING DRIVEWAY

SOUTH PARK ST.

PROPOSED NEW GARAGE

REMOVE EXISTING CURB

NEW DRIVEWAY

INTEGRAL SIDEWALK IN NEW DRIVEWAY TO BE CONT. W/ EXISTING SIDEWALK

26'-0"

±9'-6" SETBACK

24'-0"

PROPERTY LINE

EXISTING SIDEWALK

SITE PLAN

3/32" = 1'-0"

VARNER GARAGE

MT. VERNON, OH

STATE of OHIO
KNOX COUNTY
CITY OF MOUNT VERNON
LOT 467 of the
THOMAS ADDITON~PB. P Pg. 517
TOWNSHIP 6 NORTH
RANGE 13 WEST
U.S. MILITARY LANDS

**Location Survey for
Stacey Varner**

"Bearing are based on the Ohio State Plane Coordinate System,
Ohio North Zone, NAD83, as established by Static and RTK GPS
Observations, and was determined by using NGS, OPUS-S Service,
with the South Right of Way of East Gambier Street as bearing South
86° 11' 02" East and are used to denote angles only."

East Gambier Street ~ 66' R/W

South Park Street ~ 49.5' R/W

Lot 466

Jeffrey C & Cindy D Northrup
1465 / 452
0.200 Ac.

N 03°58'16" E
132.00'

S 86°11'02" E
66.00'

Lot 467

2 Story House

MR Stacey Varner
Parcel # 66-03347.000
1811 / 94
0.200 Acres by Survey

N 86°11'02" W
66.00'

Lot 469

Edith M Cosner
309 / 162
0.200 Ac.

205 Park Street LLC
1835 / 794
0.067 Ac.

Lot 468

Legend

○ = 5/8" x 30" Rebar with a 2" Aluminum ID cap
stamped "Boeshart S-6512" set

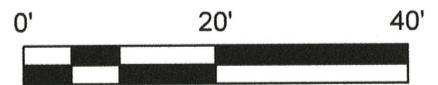

Scale: 1" = 20'

I HEREBY CERTIFY THAT THIS PLAT REPRESENTS A TRUE AND CORRECT
SURVEY AND ALL MEASUREMENTS WERE MADE IN ACCORDANCE WITH
CHAPTER 4733-38 OF THE OHIO ADMINISTRATIVE CODE UNDER MY
DIRECT SUPERVISION IN MAY, 2021.

PAUL J. BOESHART, PLS REGISTRATION NO. S-6512
94 CANYON VILLA DRIVE, HEBRON, OH 43025
PHONE: 740-928-4130 CELL: 740-616-0812 EMAIL: pjbboeshart@hotmail.com

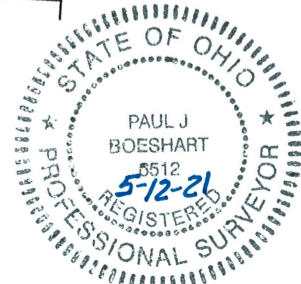

Attachment: 21-6622 - 306 e gambier - location-survey_PaulBoeshartLandSurveyor (2340 : 2021-Hrc-14)