



Board of Zoning Appeals  
Board Meeting

Minutes

March 6, 2024  
5:30 PM

**VIDEO BROADCASTING & RECORDING**

**CALL TO ORDER**

Attendee Name	Title	Status
Michael Percy	Chairman	Present
Susie Simpson	Vice-Chair	Present
William Smith	Member	Present
Otho Eyster	Alt. Member	Present
Tonya Boucher	Member	Present
Kate Aryanata	Alt. Member	Excused
Cynthia Cunningham	Member	Present

Others in attendance: City Development Services Manager, Lacie Blankenhorn; City Law Director, P. Rob. Broeren; Mike Hillier; Mel Severns; Cheryl Splain; Robin Peck; James Mahan; Max Hentosh; Grant Ritchey

**MINUTES APPROVAL**

- Board of Zoning Appeals - Board Meeting - Feb 21, 2024 5:30 PM

<b>RESULT:</b>	<b>ACCEPTED [5 TO 0]</b>
<b>MOVER:</b>	William Smith, Member
<b>SECONDER:</b>	Susie Simpson, Vice-Chair
<b>AYES:</b>	Percy, Simpson, Smith, Boucher, Cunningham
<b>ABSTAIN:</b>	Eyster
<b>EXCUSED:</b>	Aryanata

**PUBLIC HEARINGS**

- 2024-BZA-05 Variance request for parking count at 117 E High ST
- 2024-BZA-06 Variances request for 808 Coshocton AVE parking count and setbacks

**BZA FILES**

- 2023-BZA-22 : Bylaws

Cunningham made a motion to table this case to the next BZA meeting, TBD. Boucher seconded the motion. Vote: AIF

**RESULT: TABLED**

- 2024-BZA-05 : 117 E High St - Variance for Parking Count

Hentosh (sworn in) of MKC Architects, hired by the Knox County Commissioners, explained their plan for an addition to the north entry and loading dock at the Knox County Service Center. The existing building does not meet Code required parking count and there is no known variance to permit this. The proposed addition would require additional parking to be added. The addition is an 1,100 square feet loading dock enclosure and new pass-through vestibule. The variance request is to approve the existing parking count of 273 without adding any additional spaces.

Blankenhorn read the staff report: March 6, 2024 Case: 2024-BZA-05 117 E High ST Parcel # 66-50451.000 The subject property is zoned O/I - Office-Institutional District. The proposed development is a new pass-through lobby and loading dock enclosure to the back of the building, facing Chestnut ST. The property is currently developed with an office building converted from a hospital. Parking is provided on adjacent lots. Additional on-street parking is also available. Off-street parking regulations requires 1 parking space for each 200 square feet of floor area. The proposed addition triggers the requirement to add 10 parking spaces. A variance is requested to waive this requirement and continue utilizing the existing 273 provided spaces. A visit to the building during standard business hours shows parking availability. The proposed addition will be vetted by the Historical Review Commission on March 14.

Boucher made a motion to approve the variance request as presented.

**RESULT: ACCEPTED [4 TO 0]**  
**MOVER:** Tonya Boucher, Member  
**SECONDER:** William Smith, Member  
**AYES:** Smith, Eyster, Boucher, Cunningham  
**EXCUSED:** Aryanata  
**RECUSED:** Percy, Simpson

- 2024-BZA-06 : 808 Coshocton AVE - Variances for Parking Count and Setbacks

Peck (sworn in) of Valvoline, explained their variance request for setbacks of the pavement and dumpster enclosure.

The originally requested variance for parking count is not needed due to classifying the operation as a service center and not a repair facility.

Peck explained access around the entire building is being provided to meet codes and do allow for automobile circulation. The side yard setbacks are critical to maintain the lane widths. The dumpster location is for easy access.

Percy clarified the side setbacks would be reduced from 10' to 1' 11" on one side and to 2' 7" on the other side. Peck said there is currently just a curb that separates the neighboring O'Reilly's property from the subject parcel. On the other side there is a small strip of landscaping at the bank and a narrow gap with a pseudo curb. Peck said landscaping with sod and a couple of trees will be added to the site. It won't be all impervious. Blankenhorn read the staff report: March 6, 2024 Case: 2024-BZA-06 808 Coshocton AVE Parcel # 66-07558.000 The subject property is zoned GB - General Business District. The proposed use is an instant oil change facility. The property is currently developed with asphalt to the property line on the west side and the primary structure is 3.3 feet from the east property line. The building has been vacant since 2014. GB

Development Standards require a minimum side yard setback of 10 feet for pavement and 15 feet for structures. A variance is requested for reduced side setbacks for pavement of 1' 11" on the east side and 2' 7" on the west side. A variance is requested for a reduced side setback for a structure, the dumpster enclosure, of 2' 7" on the west side. The proposed use should be categorized as a motor vehicle service station as opposed to a motor vehicle repair station. City Code requires 2 parking spaces for each service bay of a service station. The 2 proposed bays would require 4 parking spaces. The 11 provided parking spaces, including 1 accessible space, would not require the requested variance, if the operation is categorized as a service station and not a repair station.

Simpson made a motion to accept the proposal as presented for side setbacks.

<b>RESULT:</b>	<b>ACCEPTED [UNANIMOUS]</b>
<b>MOVER:</b>	Susie Simpson, Vice-Chair
<b>SECONDER:</b>	Cynthia Cunningham, Member
<b>AYES:</b>	Percy, Simpson, Smith, Boucher, Cunningham
<b>EXCUSED:</b>	Eyster, Aryanata

**ADJOURN**

- Adjourn Motion

Boucher made a motion to adjourn the meeting, Cunningham seconded and the meeting was adjourned at 5:43 PM

<b>RESULT:</b>	<b>ADOPTED [UNANIMOUS]</b>
<b>MOVER:</b>	Tonya Boucher, Member
<b>SECONDER:</b>	Cynthia Cunningham, Member
<b>AYES:</b>	Percy, Simpson, Smith, Boucher, Cunningham
<b>EXCUSED:</b>	Eyster, Aryanata



**Board of Zoning Appeals** Meeting: 03/06/24 5:30 PM  
**City of Mount Vernon Dept: Board of Zoning Appeals**  
**Mount Vernon, OH 43050**

**TABLED**

Category: N/A  
 Prepared By: Lacie Blankenhorn  
 Initiator: Lacie Blankenhorn

**BZA FILE (ID # 3890)**

**DOC ID: 3890**

### **2023-BZA-22 : BYLAWS**

Item Number	2023-BZA-22
Site Address	N/A
Parcel Number	N/A
Zoning District	N/A
Presented By	Matthew T. Starr, Chairman

Quick Guide to Codified Ordinance Sections (may not be inclusive):

1155.05(b) Board of Zoning Appeals: The Board of Zoning Appeals may adopt rules and regulations governing the conduct of its affairs that are consistent with this Zoning Ordinance.

Request: Review proposed bylaws for adoption

#### **HISTORY:**

11/01/23 Board of Zoning Appeals TABLED Next: 02/21/24

Blankenhorn explained that the City Administration would like each Board & Commission to have Bylaws. The draft proposed by the Mayor is in the agenda packet for this Board to review and provide feedback and discuss during a future meeting.

Boucher made a motion to table the Bylaws review and discussion. Aryanata seconded and voting was AIF.

02/21/24 Board of Zoning Appeals TABLED Next: 03/06/24

Blankenhorn explained that the bylaws were introduced in November 2023 and then tabled. The mayor is proposing bylaws for all committees of the City. Essentially, they look very similar from one board to the next. There are a couple of clarifications that are needed based on your preferences. The first edit is in Article 6, letter A, the link is inaccurate and Blankenhorn proposed Section 1155.10 which goes over the requirements for an appeal. The second item is wording that needs a decision in Article 7, Letter J. Shall or may is proposed.

Percy asked if there was any communication regarding the proposed bylaws.

Blankenhorn explained the Law Director brought attention to the mentioned link.

An email from Mike Hillier was read: Please share this with the zoning board in a timely manner prior to tonight's meeting. (Blankenhorn chose not to forward the email prior to the meeting, knowing not every member would see it in time.) At tonight's meeting you are asking the board of zoning appeals to approve bylaws for this commission. Although I understand the reason for

bylaws I do think there should be two changes prior to passage. Article 7 Section (J) The Board of Zoning Appeals shall/may allow time for public comments during the meeting. The Chair may limit the length of time of any individual speaker. I feel it is very important you do not eliminate the public from participating in your meeting. It is for the public's good that you have zoning appeals. Although your intentions may be different than some may interpret, I think you and this board need to strike out the word may (shall/may) and set an allotted time for the person to speak. Similar to city council. They allow 4 minutes and the person speaking may ask the board for more time if needed. It is very important that we do not take away the voice of the public. Those you represent. Feel free to call with any questions or concerns. Thank you for your consideration in this matter. Mike Hillier

An email from Bob and Linda Beck was read: Lacie & Todd, I would like the following read at tonight's, Feb 21 Zoning Appeals Board Meeting for the permanent record. I am very concerned by the Mayor's proposed bylaws, specifically ARTICLE 7. Meetings Line J text as follows : (J) The Board of Zoning Appeals shall/may allow time for public comments during the meeting. The Chair may limit the length of time of any individual speaker. I strongly believe everyone who has a concern or comment about a specific zoning change request MUST be heard. How else can this Board rationally vote on the proposed change. The 'people' being affected must have the opportunity to voice additional facts and their opinion on any requested change.

Percy conveyed his opinion, stating the way he reads this section of the bylaws, is not to limit comments on a case, but on comments not related to a case. There have been instances of people complaining rather than addressing the business before the Board at the time. Percy said he is fully on board with giving people time, but not to be scolded. Percy does not agree with limiting time on a case or not allowing comments on a case. General public comments have gotten excessive.

Hillier (sworn in) spoke of City Council adding a time limit to those speaking on matters pertaining to the City. Hillier thinks limiting comment to case matter could be written into the bylaws. He thinks issues could arise by allowing the chairman to limit speaking time versus City Council's allotted 4 minutes. Percy said he agrees with including a time limit. Percy said he would not limit speaking time on a case, but rather on general public comments. Hillier said he thinks the bylaw needs to be written in a way that clearly states anyone in attendance that wants to speak about the case has that ability.

Cunningham said she thinks they agree. They will likely go with shall, then divide the bylaw into two parts; one for case public comment, and one for general issues. The latter will probably have a time limit.

Hillier asked, when the word shall is used, does that mean you will. Cunningham said yes. Broeren said it's mandatory. Eyster said there's no choice, it's mandatory. Cunningham said that they have to.

Percy said he agrees with shall. He thinks case comments should have a larger time limit. Broeren said it sounds like item J needs more work and suggested tabling the matter to be revisited. Percy suggested limiting general comments to 4 minutes and comments specific to a

case to be limited to 10 minutes. Eyster wasn't sure a differentiation is necessary. Cunningham said she doesn't want a half hour lecture on how to do her job on the BZA. Eyster suggested the chair allow the same amount of time to anyone wanting to speak.

Cunningham made a motion to table. Smith seconded. Voting was AIF.

**COMMENTS - Current Meeting:**

Cunningham made a motion to table this case to the next BZA meeting, TBD. Boucher seconded the motion. Vote: AIF

**RESULT:      TABLED**



## BYLAWS OF THE

*Board of Zoning Appeals for the City of Mount Vernon, Ohio*

### ARTICLE 1. NAME

The name of the board is *BOARD OF ZONING APPEALS*. (Ordinances 1155)

### ARTICLE 2. PURPOSE AND DUTIES (1155.08)

- (A) The Board of Zoning Appeals may adopt rules and regulations governing the conduct of its affairs that are consistent with the Zoning Ordinance of the City of Mount Vernon. All rules and regulations shall be filed with the Clerk of Council and made available for public inspection. The Board of Zoning Appeals shall annually choose from its membership a chairman and vice-chairman. (Ord. 2014-08. Passed 4-28-14.)
- (B) In exercising its duties, the Board may, as long as such action is in conformity with the terms of the bylaws and the Zoning Ordinance from which they were developed reverse or affirm, wholly or partly, or modify the order, requirements, decision, or determination appealed from and may make such order, requirement, decision, or determination as ought to be made. At such time, to that end shall have the powers of the Zoning Enforcement Officer from whom the appeal is taken. For the purpose of the bylaws according to the Zoning Ordinance the Board has the following specific responsibilities:
- (a) To hear and decide appeals where it is alleged there is an error in any order, requirement, decision, interpretation, or determination made by the Zoning Enforcement Officer.
  - (b) To authorize such variances from the terms of the bylaws as will not be contrary to the public interest, where, owing to the special conditions, a literal enforcement of the bylaws and/or zoning ordinance will result in unnecessary hardship, and so that the spirit of the bylaws and/or zoning ordinance shall be observed and substantial justice done.

- (c) To grant conditional use permits as specified in the Schedule of District Regulations and under the conditions specified in Section [1155.22](#) and such additional safeguards as will uphold the intent of the bylaws.
- (d) To hear and decide requests for the interpretation of the Zoning Map.
- (C) Members of the Board of Zoning Appeals shall serve without pay. (Ord. 1990-11. Passed 4-16-90.)
- (D) An individual board member may not act in an official capacity except through the action of the board.
- (E) Members are expected to let the City Clerk know if there are any conflicts of interest regarding the business set forth on the agenda or that may arise in a meeting.

### **ARTICLE 3. MEMBERSHIP**

- (A) The Board of Zoning Appeals shall consist of five (5) members to be appointed by the Mayor, and approved by City Council. The term of all members shall be five (5) years and their terms shall be so arranged that the term of one (1) member shall expire each year.
- (B) The Mayor shall also appoint two alternate members, with the approval of City Council, who may be called upon by the chairman to hear appeals if a member is unavailable or has a conflict of interest.
- (C) Each member shall serve until his successor is appointed and qualified.
- (D) Members of the Board shall be removable for nonperformance of duty, misconduct in office, or other reasonable cause by the Mayor upon written charges and after a public hearing has been held regarding such charges, a copy of the charges having been served upon the member so charged at least ten (10) days prior to the hearing either personally or by registered mail, or by leaving the same at his place of residence. The member shall be given an opportunity to be heard and answer such charges.
- (E) Vacancies shall be filled by appointment by the Mayor, with the approval of council, and shall be for the unexpired term.
- (F) Attendance - members are expected to let the City Clerk know if they are not able to attend the meetings.

- (G) The Board of Zoning Appeals may adopt rules and regulations governing the conduct of its affairs that are consistent with the bylaws and the zoning ordinances from which they were drawn. All rules and regulations shall be filed with the Clerk of Council and made available for public inspection.
- (H) The chair, or in his absence the vice-chair, shall advise Council by letter if any Board of Zoning Appeals member has absented himself from all meetings held during any period of ninety consecutive days or who has absented himself from a total of one-fourth of the regular meetings during a calendar year. Council shall consider removing such a member.
- (I) A member who seeks to resign from the Commission shall submit a written resignation to their appointing authority. If possible, the resignation should allow for a thirty day notice so the appointing authority can appoint a replacement.

## **ARTICLE 4. OFFICERS**

- (A) The officers of the board shall consist of the Chair and the Vice-chair.
- (B) The Board of Zoning Appeals shall annually choose from its membership a chairman and vice-chairman.

## **ARTICLE 5. DUTIES OF OFFICERS**

- (A) The Chair shall preside at board meetings and approve each final meeting agenda.
- (B) In the absence of the Chair, the Vice-chair shall perform all duties of the Chair.

## **ARTICLE 6. AGENDAS**

- (A) Upon receipt of an application for a zoning appeal, which is accompanied by the material required by the provisions of subsection [1172.1155.23](#) of the codified ordinances of the City of Mount Vernon, the Zoning Enforcement Officer or his designee shall place the application on the agenda for the Board of Zoning Appeals at its next regular meeting following 30 days from the date the application is filed. The Zoning Enforcement Officer (or designee) shall further cause to be published in a newspaper of general circulation in the City, a public notice of the scheduled hearing of the application together with a general description of the nature of the application. The applicant shall be notified by

mail of the date of the hearing.

(B) Agendas are published on the City's website.

## ARTICLE 7. MEETINGS

(A) Board meetings shall comply with the Ohio Open Meetings Act (ORC 121.22).

(B) Board meetings shall be governed by Robert's Rules of Order.

(C) Board may not conduct an executive session without the approval of the Law Director.

(D) The Board shall meet monthly on the first and third Wednesday of the month at 5:30 p.m. in Council Chambers (40 Public Square) or when it is required to meet in order to comply with a legal deadline.

(E) No later than December of each year, the Board shall adopt a schedule of the meetings for the upcoming year, including makeup meeting dates for the holidays and canceled meetings.

(F) The Chair may call a special meeting, and the Chair shall call a special meeting if requested by three or more members. The call for the meeting shall state the purpose of the meeting.

(G) Four members constitute a quorum.

(H) If a quorum for a meeting does not convene within twenty (20) minutes of the posted time for the meeting, then the meeting may not be held.

(I) To be effective, a board action must be adopted by an affirmative vote of the majority of the members present.

(J) The Board of Zoning Appeals shall/may allow time for public comments during the meeting. The Chair may limit the length of time of any individual speaker.

(K) The Zoning Enforcement Officer (or designee) shall prepare the Board meeting minutes. The minutes of each Board meeting must include the vote of each member on each item before the Board and indicate whether a member is absent or failed to vote on an item.

(L) The city shall retain documents of the Board of Zoning Appeals pursuant to its written records retention policy as approved by the Ohio History Connection.

(M)Each person and Board member attending a Board meeting should act appropriately and professionally.

### ARTICLE 8. PARLIAMENTARY AUTHORITY

The rules contained in the current edition of Robert's Rules of Order shall govern the board in all cases to which they are applicable, except when inconsistent with these bylaws.

### ARTICLE 9. AMENDMENT OF BYLAWS

A bylaw amendment is not effective unless approved by a majority of the members of the Board of Zoning Appeals. Furthermore, amendments may not apply to statutory requirements of the Ohio Revised Code.

The Board of Zoning Appeals bylaws were approved by the Board of Zoning Appeals meeting held on \_\_\_\_\_(date/time) at CITY HALL, 40 PUBLIC SQUARE, MOUNT VERNON, OHIO (location) .

*(Signature of Board of Zoning Appeals Chair)*

*Board of Zoning Appeals members present:*

Attachment: Board of Zoning Appeals Bylaws 04122023 - Google Docs DRAFT (3890 : 2023-Bza-22)



**Board of Zoning Appeals** Meeting: 03/06/24 5:30 PM  
**City of Mount Vernon Dept: Board of Zoning Appeals**  
**Mount Vernon, OH 43050**

ADOPTED Prepared By: Lacie Blankenhorn  
 Initiator: Lacie Blankenhorn

Category: N/A

**BZA FILE (ID # 3974)**

**DOC ID: 3974**

**2024-BZA-05 : 117 E HIGH ST - VARIANCE FOR PARKING COUNT**

Item Number	2024-BZA-05
Site Address	117 E High ST
Parcel Number	66-50451.000
Zoning District	O/I
Presented By	Max Hentosh, MKC Architects for Knox County Commissioners

Quick Guide to Codified Ordinance Sections (may not be inclusive):  
 1174.05 Required Number of Parking Spaces By Use

Request: a variance for a reduced number of required parking spaces

**COMMENTS - Current Meeting:**

Hentosh (sworn in) of MKC Architects, hired by the Knox County Commissioners, explained their plan for an addition to the north entry and loading dock at the Knox County Service Center. The existing building does not meet Code required parking count and there is no known variance to permit this. The proposed addition would require additional parking to be added. The addition is an 1,100 square foot loading dock enclosure and new pass-through vestibule. The variance request is to approve the existing parking count of 273 without adding any additional spaces.

Blankenhorn read the staff report: March 6, 2024 Case: 2024-BZA-05 117 E High ST Parcel # 66-50451.000 The subject property is zoned O/I - Office-Institutional District. The proposed development is a new pass-through lobby and loading dock enclosure to the back of the building, facing Chestnut ST. The property is currently developed with an office building converted from a hospital. Parking is provided on adjacent lots. Additional on-street parking is also available. Off-street parking regulations requires 1 parking space for each 200 square feet of floor area. The proposed addition triggers the requirement to add 10 parking spaces. A variance is requested to waive this requirement and continue utilizing the existing 273 provided spaces. A visit to the building during standard business hours shows parking availability. The proposed addition will be vetted by the Historical Review Commission on March 14.

Boucher made a motion to approve the variance request as presented.

**RESULT:** ACCEPTED [4 TO 0]  
**MOVER:** Tonya Boucher, Member  
**SECONDER:** William Smith, Member  
**AYES:** William Smith, Otho Eyster, Tonya Boucher, Cynthia Cunningham  
**EXCUSED:** Kate Aryanata  
**RECUSED:** Michael Percy, Susie Simpson



City of Mount Vernon, Ohio  
Board of Zoning Appeals

Request for Hearing

**Applicant's Information**

Owner's Name, Address and Phone

Agent's Name, Address and Phone

**Site Information**

Site Address

Legal Description

Parcel Number

Deed Volume and Page Number

Zoning District

Existing use of property

Proposed use of property

**Hearing Request**

**Type of Hearing Requested**

Variance       Conditional Use       Appeal of Decision       Map Interpretation       Substantially Similar Use

In the following section, please list a brief description of the request. Narrative statements and any additional documents or information required by the Zoning Code and Chapter 1155 should be attached to this application as separate sheets.

Request:

I hereby certify that the information submitted on this application and on any sketches, drawings or other documents submitted with this application is true and exact.

Date:

By:

**Status of Application**

Filing Date

Case Number

Hearing Date

Fee deposit

Date Paid

Receipt Number

**\$100.00**

Status of Board's Action

Approved

Denied

Attachment: kcscna\_mt.\_vernon\_request\_for\_hearing\_bza (3974 : 2024-Bza-05)

### Narrative statements

*establishing and substantiating that the variance conforms to the following standards:  
(initial beside the number to signify agreement; provide narrative for #3 & 4)*

\_\_\_\_\_ 1) The granting of the variance shall be in accord with the general purpose and intent of the regulations imposed by this Zoning Ordinance on the district in which it is located, and shall not be injurious to the area or otherwise detrimental to the public welfare.

\_\_\_\_\_ 2) The granting of the variance will not permit the establishment of any use which is not otherwise permitted in the district.

3) Describe the special circumstances or conditions, applicable to the land or buildings for which the variance is sought, which are peculiar to such land or buildings and do not apply generally to land or buildings in the area, and which are such that the strict application of the provisions of this Zoning Ordinance would deprive the applicant of the reasonable use of such land or building. There must be deprivation of beneficial use of land.

4) Explain the proof of hardship created by the strict application of this Zoning Ordinance.

\_\_\_\_\_ 5) The granting of the variance is necessary for the reasonable use of the land or building, and the variance as granted is the minimum variance that will accomplish this purpose.

\_\_\_\_\_ 6) The proposed variance will not impair an adequate supply of light and air to adjacent property, substantially increase the congestion in the public streets, increase the danger of fire, endanger the public safety, or substantially diminish or impair property values of the adjacent area.

\_\_\_\_\_ 7) The granting of the variance requested will not confer on the applicant any special privilege that is denied by this regulation to other lands, structures, or buildings in the same district.

THIS DRAWING SHALL NOT BE REPRODUCED, PUBLISHED, STORED IN AN ELECTRONIC RETRIEVAL SYSTEM, OR USED IN ANY WAY WITHOUT WRITTEN PERMISSION OF THE ARCHITECT. COPYRIGHT © MKC ARCHITECTS



161 North 4th Street  
Columbus, OH 43215  
666.675.7584  
www.mkcinc.com

CONSULTANTS

### GENERAL PARCEL INFORMATION

PARCEL NUMBER: 6650451000  
PARCEL WIDTH: 172'-4" +/-  
PARCEL DEPTH: 264'-0"  
ZONING DISTRICT: O1  
EXISTING BUILDING SF: 95,060  
EXISTING PARKING SPACES: 273  
EXISTING PARKING LOAD REQ'D BY CODE: 474  
PROPOSED ADDITION SF: 2100

### PARKING COUNTS

EXISTING PARKING LOT A: 128 SPACES  
128 SPACES  
  
EXISTING PARKING LOT B: 78 SPACES  
70 SPACES  
8 ADA SPACES  
  
EXISTING STREET PARKING: 67 SPACES  
27 SPACES (NORTH)  
40 SPACES (SOUTH)  
  
TOTAL EXISTING PARKING: 273 SPACES  
  
VARIANCE REQUEST TO ADD (0) ADDITIONAL PARKING SPACES.

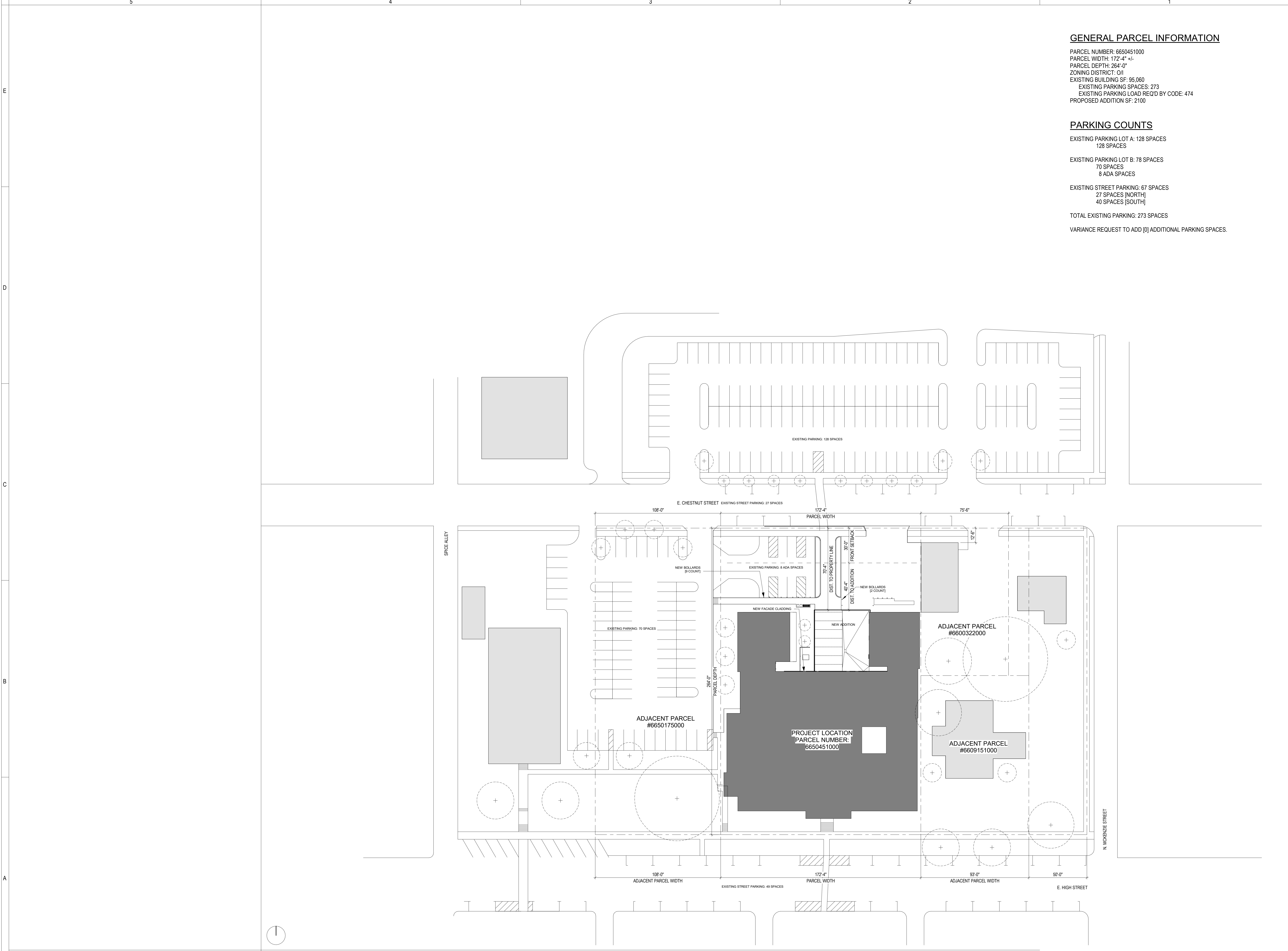

KNOX COUNTY SERVICE CENTER ENTRY ADDITION  
KNOX COUNTY COMMISSIONERS

117 E HIGH STREET, MT. VERNON, OHIO  
43050  
Attachment: kcana\_a001\_architectural\_site\_plan (3974 : 2024-82a-05)

PRELIMINARY  
NOT FOR  
CONSTRUCTION

SUBMITTED: 02.01.2024

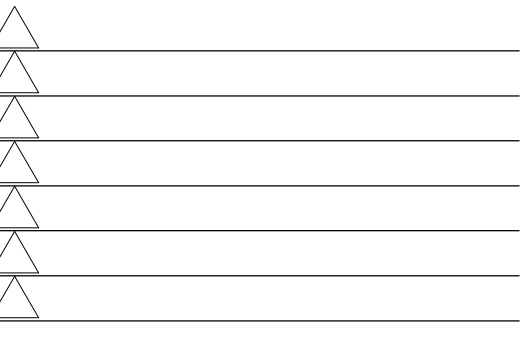

**A001**  
ARCHITECTURAL SITE PLAN

MKC PROJECT: 23-024

**A1** ARCHITECTURAL SITE PLAN  
A001 SCALE: 1" = 30'-0"

PRELIMINARY NOT FOR CONSTRUCTION

CONTRACT DOCUMENT 95% SET

2/8/2024 11:43:37 AM  
C:\Users\mhentosh\Documents\23-024\_Knox\_Service\_Center\_Entry\_Addition\_R24\_mhentosh\LBZ.ID.rvt



161 North 4th Street  
Columbus, OH 43215  
866.675.7584  
www.mkcinc.com

CONSULTANTS

KNOX COUNTY SERVICE CENTER ENTRY ADDITION  
KNOX COUNTY COMMISSIONERS

117 E HIGH STREET, MT. VERNON, OHIO  
43050  
Attachment: kcsna\_a002\_enlarged\_architectural\_site\_plan (3974; 2024-B2a-05)

PRELIMINARY  
NOT FOR  
CONSTRUCTION

SUBMITTED: 02.01.2024

A002  
SITE PLAN DETAILS

MKC PROJECT: 23-024

KEYNOTES

- 01.01 [xx xx xx] EXISTING CONCRETE SLAB TO REMAIN
- 02.01 [02 xx xx] 42" ROUND 6" DIA. FLAT TOP BOLLARD w/ FROSTED GLASS IN MATTE BLACK FINISH. MIN. 4000X LED LUMINAIRE. CONCRETE FILL w/ #5 REBAR CENTERED. EMBED MIN. 3'-0"
- 02.02 [0x xx xx] 4" SPACED EXTRUDED VERTICAL ALUMINUM FENCE. POWDERCOAT TO MATCH STANDING SEAM WALL PANELS ADJACENT.
- 02.03 [0x xx xx] NEW DROP BOX LOCATION.
- 02.04 [0x xx xx] NEW 6" BENCH. BLACK FINISH.
- 02.05 [XX XX XX] ATTACH ALUMINUM FENCE TO CONCRETE FOOTER PER MANUFACTURER'S SPECIFICATIONS
- 03.13 [XX XX XX] CONCRETE FOOTER. SEE STRUCTURAL.

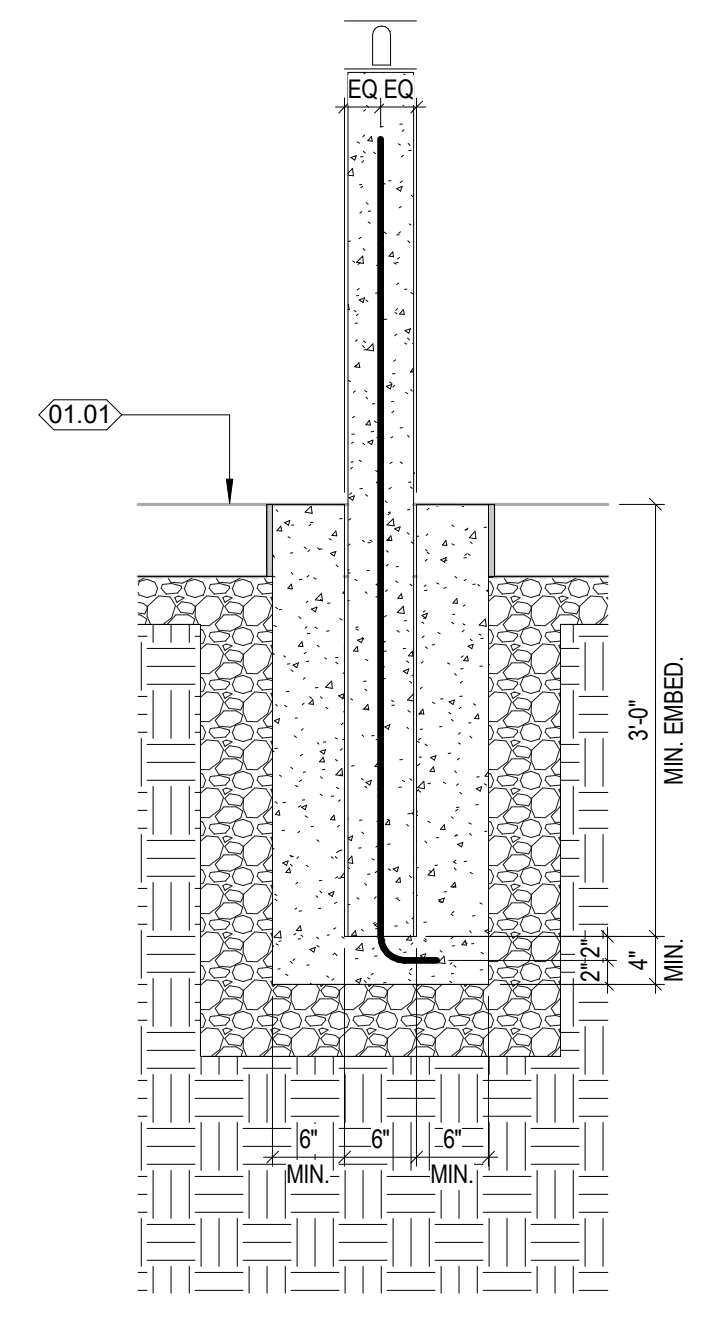

E2 SECTION DETAIL - BOLLARD, TYP.  
A002 SCALE: 3/4" = 1'-0"

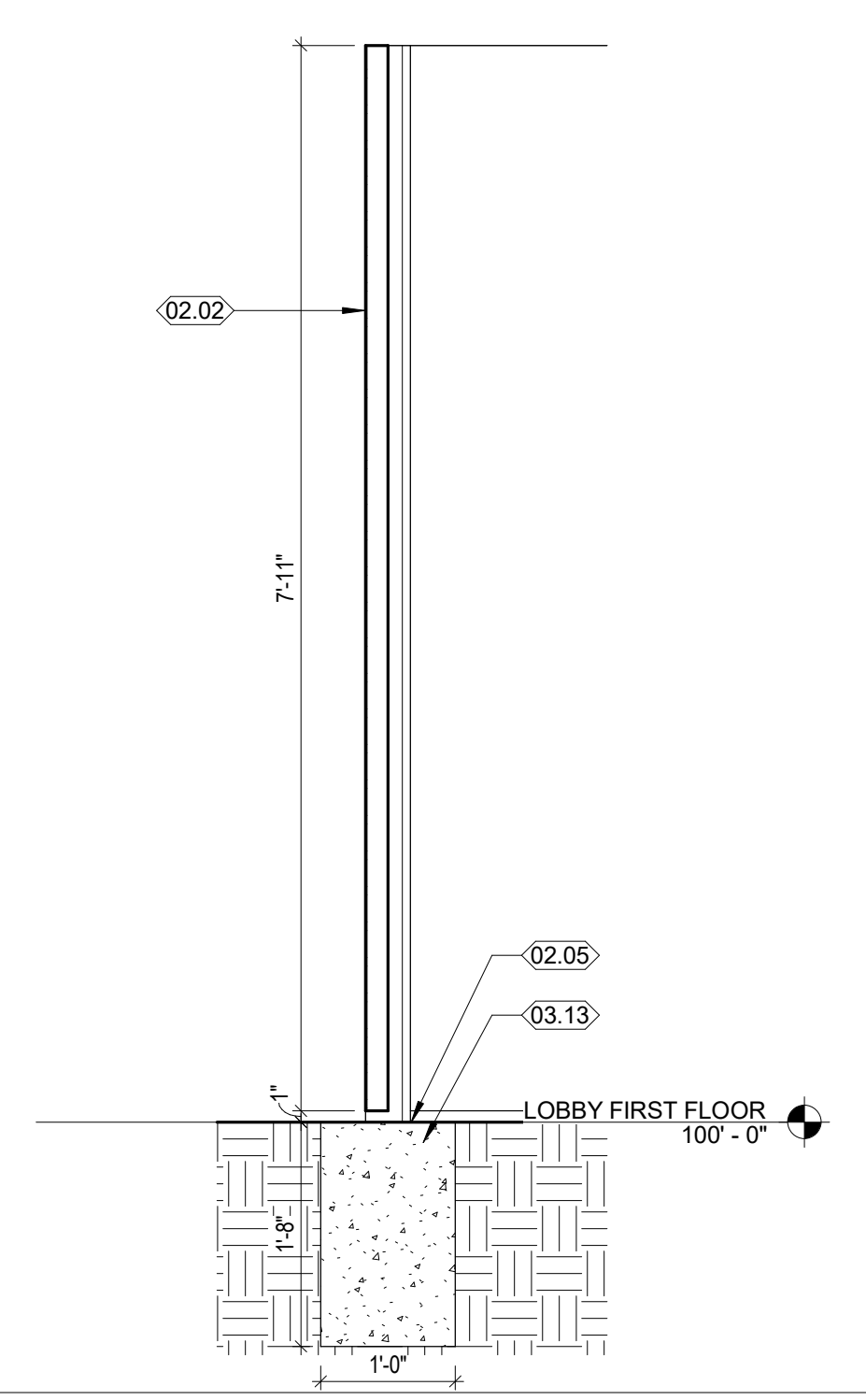

C3 TRANSFORMER SCREEN SECTION  
A002 SCALE: 3/4" = 1'-0"

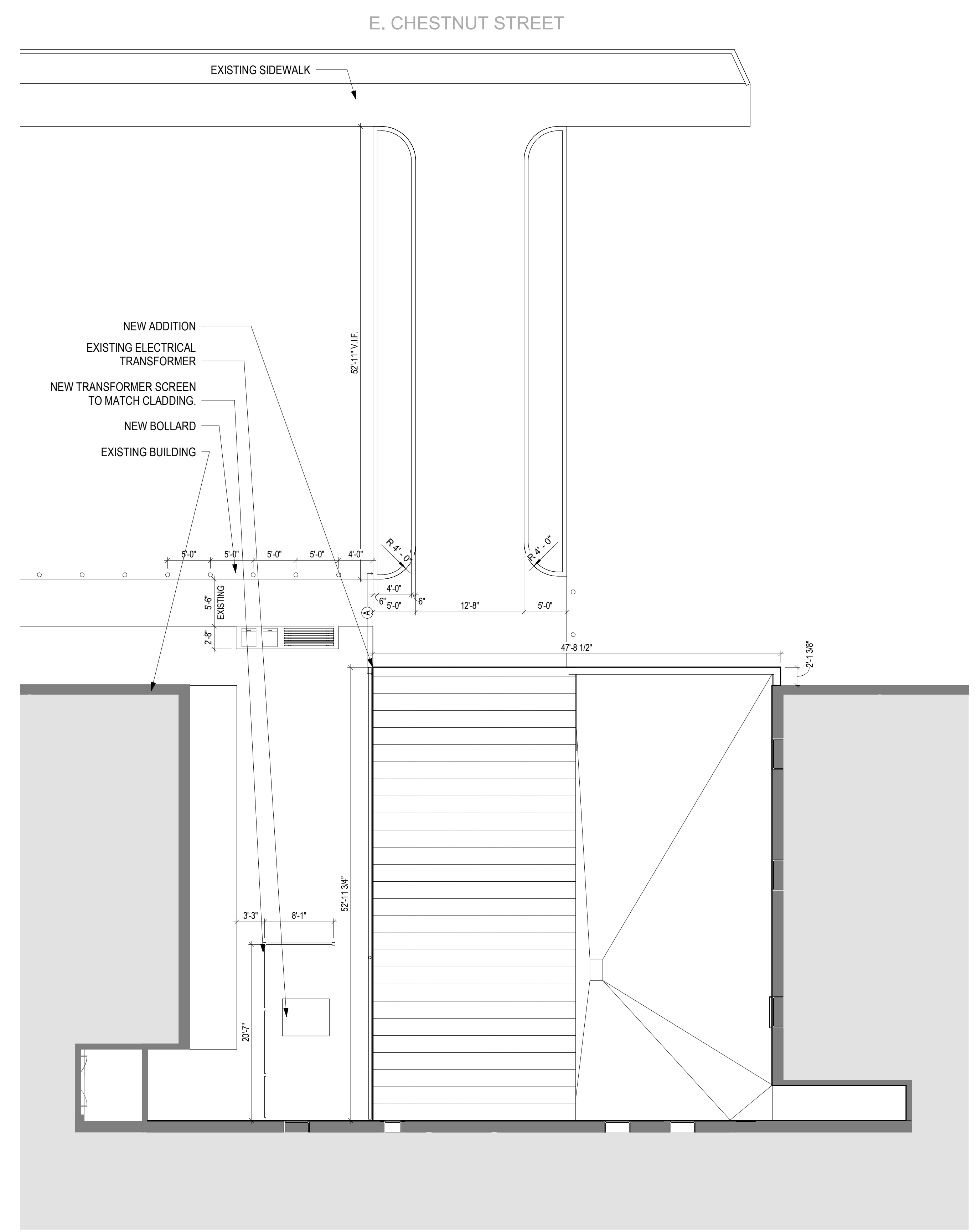

A1 ADDITION SITE PLAN  
A002 SCALE: 1/8" = 1'-0"

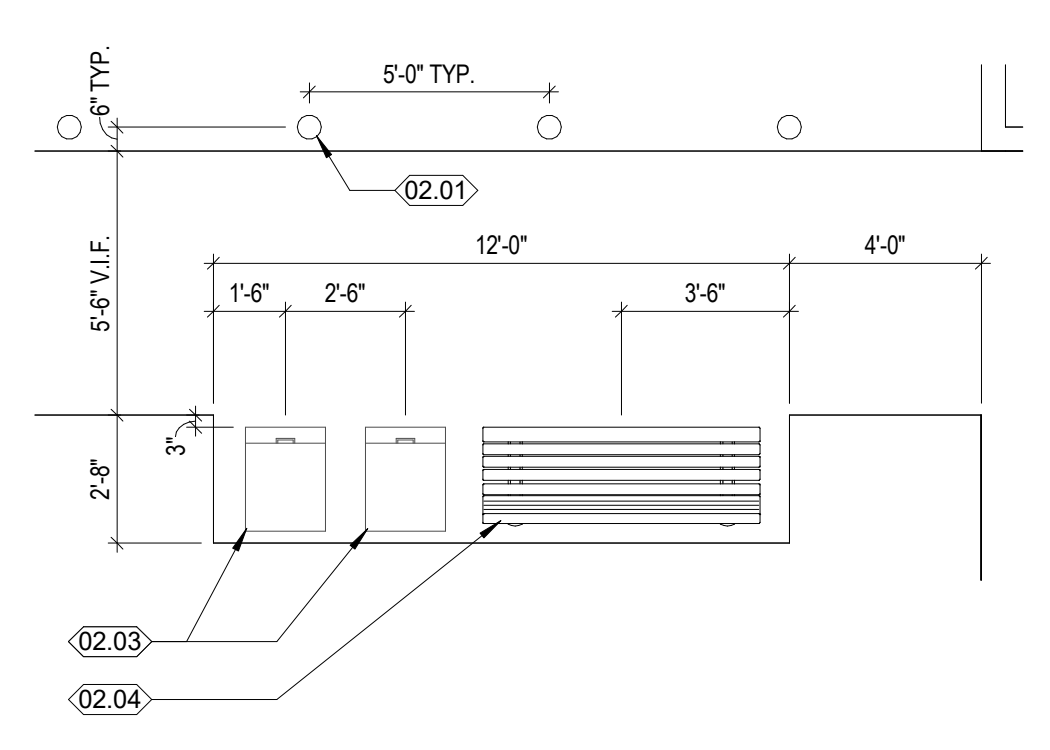

A3 ENLARGED SITE PLAN - BENCH AND DROP BOX  
A002 SCALE: 1/4" = 1'-0"

# KNOX COUNTY SERVICE CENTER NORTH ENTRY ADDITION



117 E. HIGH STREET, MT. VERNON OHIO 43050

# SUBMITTAL CONTENTS

- ] Project Narrative
- 2] Existing Conditions
- 3] Adjacent Properties
- 5] Site Plan
- 6] Site Plan : Addition
- 7] Massing Diagram
- 8] Building Elevation
- 9] Rendered Elevation
- 10] Exterior Rendering

## PROJECT NARRATIVE

The Knox County Service Center functions as the primary entry for many members of the public and employees alike. However, existing conditions cause a disconnect between the building approach, access, and entry. For this reason, The Knox County Commissioners have requested an addition design including a new lobby addition, recladding of the existing north facade, and enclosure of the adjacent loading dock.

The new addition takes its barrel-vaulted inspiration from the pedestals on the southside entry of the Service Center which function as a gateway from the street. The new recessed entryway is carved from the overall mass and highlighted with a stone-like finish. The design is inspired by the historic narrative and Mount Vernon's shaping and stone deposits of the Glaciated Allegheny Plateau which carved away land to create the ground on which Mount Vernon rests today.

An emphasis was placed on designing an entry that pulls from the historic nature of Mount Vernon, while employing a contemporary form that will define the procession for decades to come. The exterior metal panel pulls inspiration from a nearby elevator shaft addition on the Knox County Board of Elections building by request of the Commissioners. The design proposal uses the same material to re-clad the existing north wall and define a cohesive updated look to the building's commonly used entry point.





RED BRICK WILL BE PRESERVED

YELLOW BRICK FACADE TO BE RE-CLAD

CANOPY TO BE REMOVED

Attachment: historic\_review\_presentation\_2024.02.12 (3974 : 2024-Bza-05)



WEST, FACING SOUTH FROM E. SUGAR ST.  
RENOVATED 2019, METAL PANEL REFERENCE.



WEST - FACING SOUTH; WEST PARKING LOT

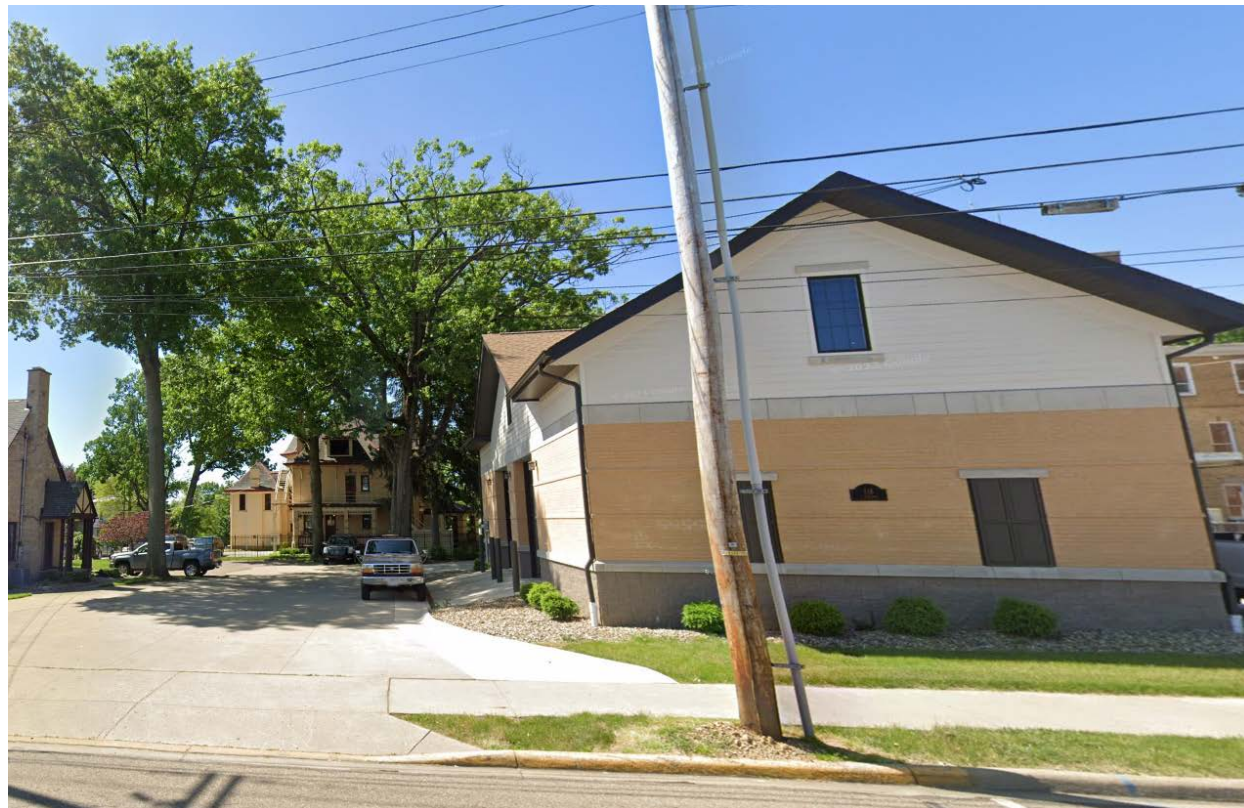

EAST - FACING SOUTH; EAST VEHICLE SERVICE BUILDING



WEST - FACING NORTH ACROSS CHESTNUT

Attachment: historic\_review\_presentation\_2024.02.12 (3974 : 2024-Bza-05)

# ADJACENT PROPERTIES



WEST, FACING NORTH FROM HIGH ST.



NORTH, FACING NORTH FROM CHESTNUT; NORTH PARKING LOT



SOUTH, FACING SOUTH FROM HIGH ST.



EAST - FACING NORTH FROM HIGH ST.

Attachment: historic\_review\_presentation\_2024.02.12 (3974 : 2024-Bza-05)

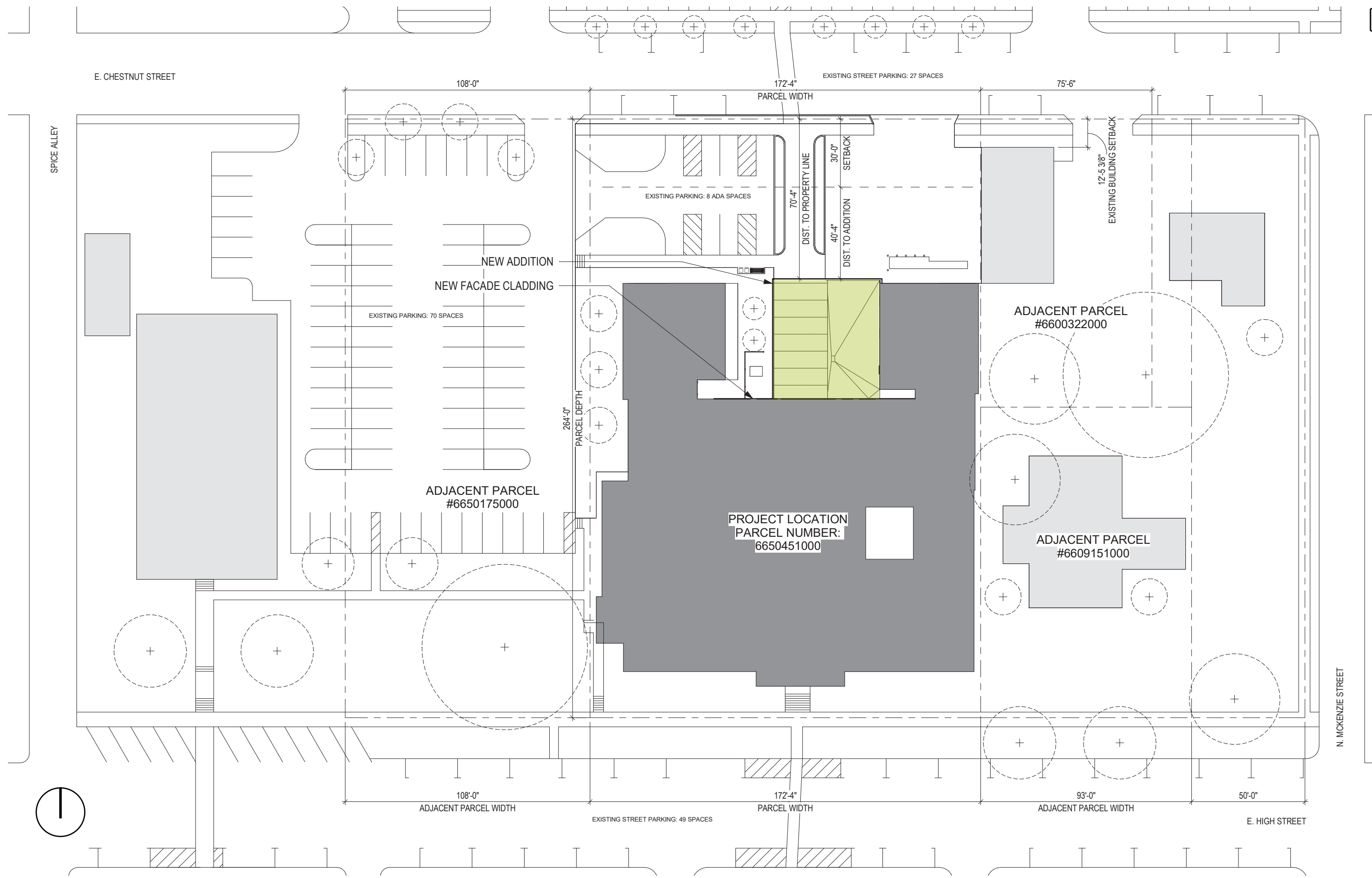

Attachment: historic\_review\_presentation\_2024.02.12 (3974 : 2024-Bza-05)

# SITE PLAN

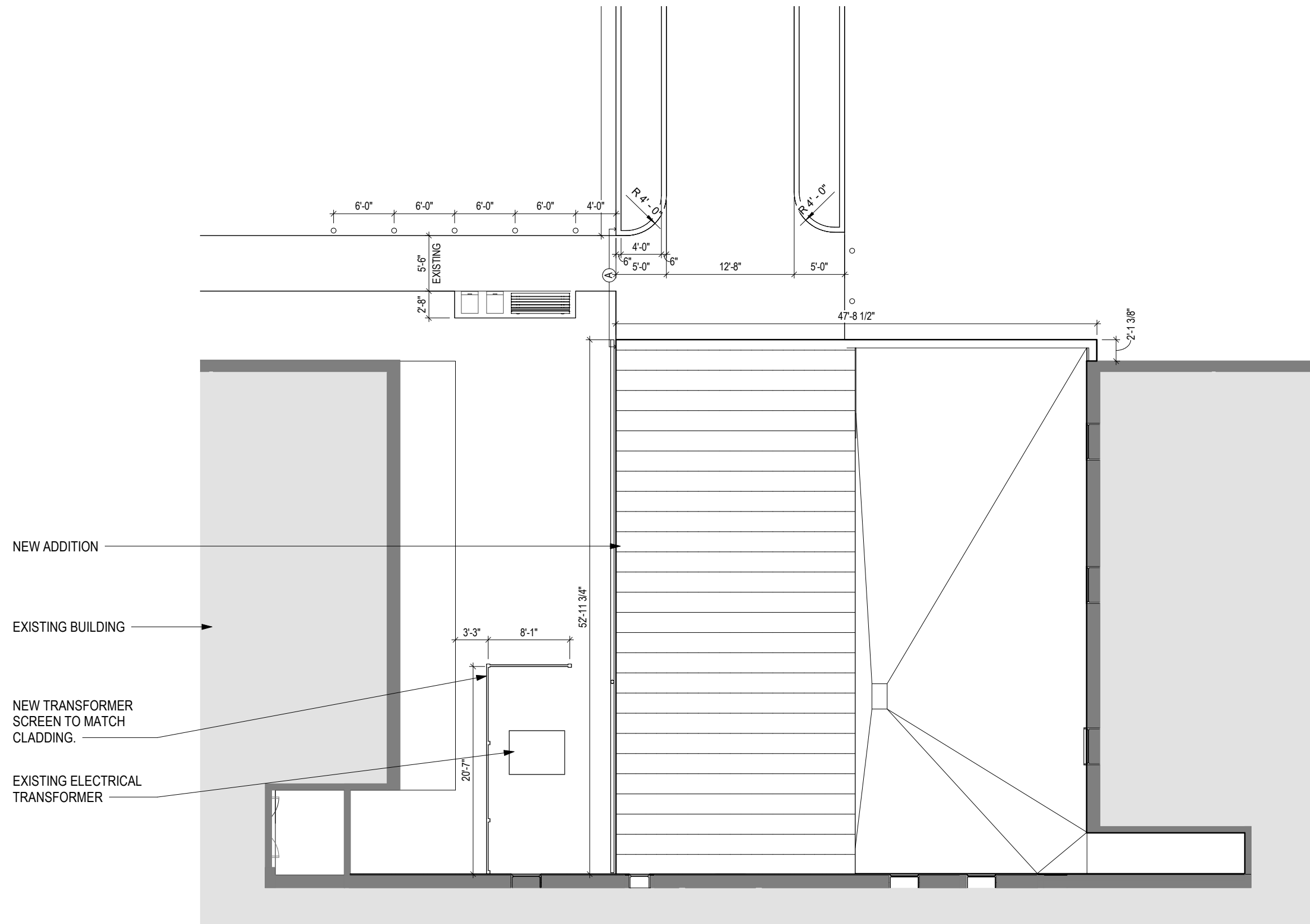

Attachment: historic\_review\_presentation\_2024.02.12 (3974 : 2024-Bza-05)

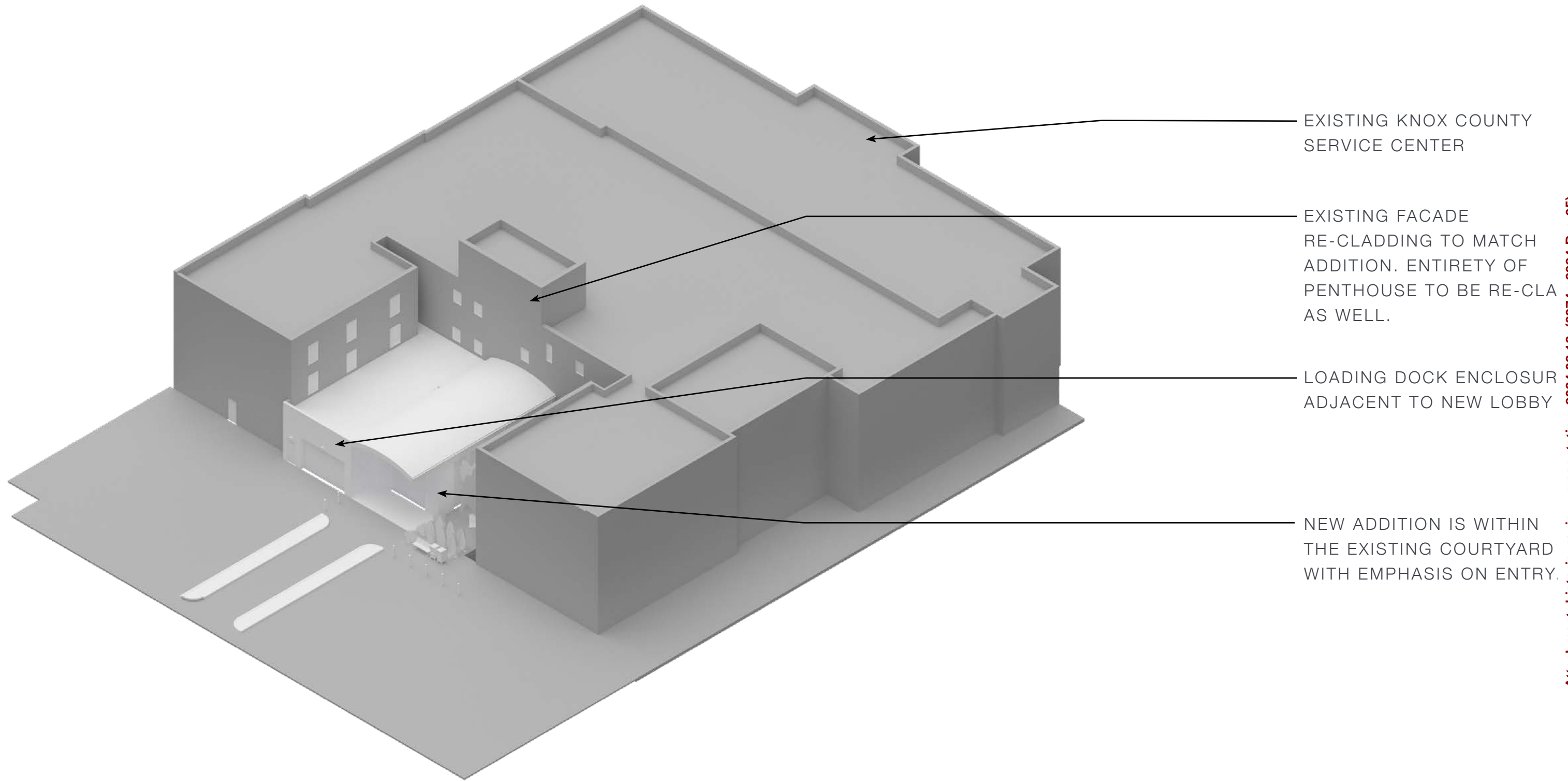

Attachment: historic\_review\_presentation\_2024.02.12 (3974 : 2024-Bza-05)



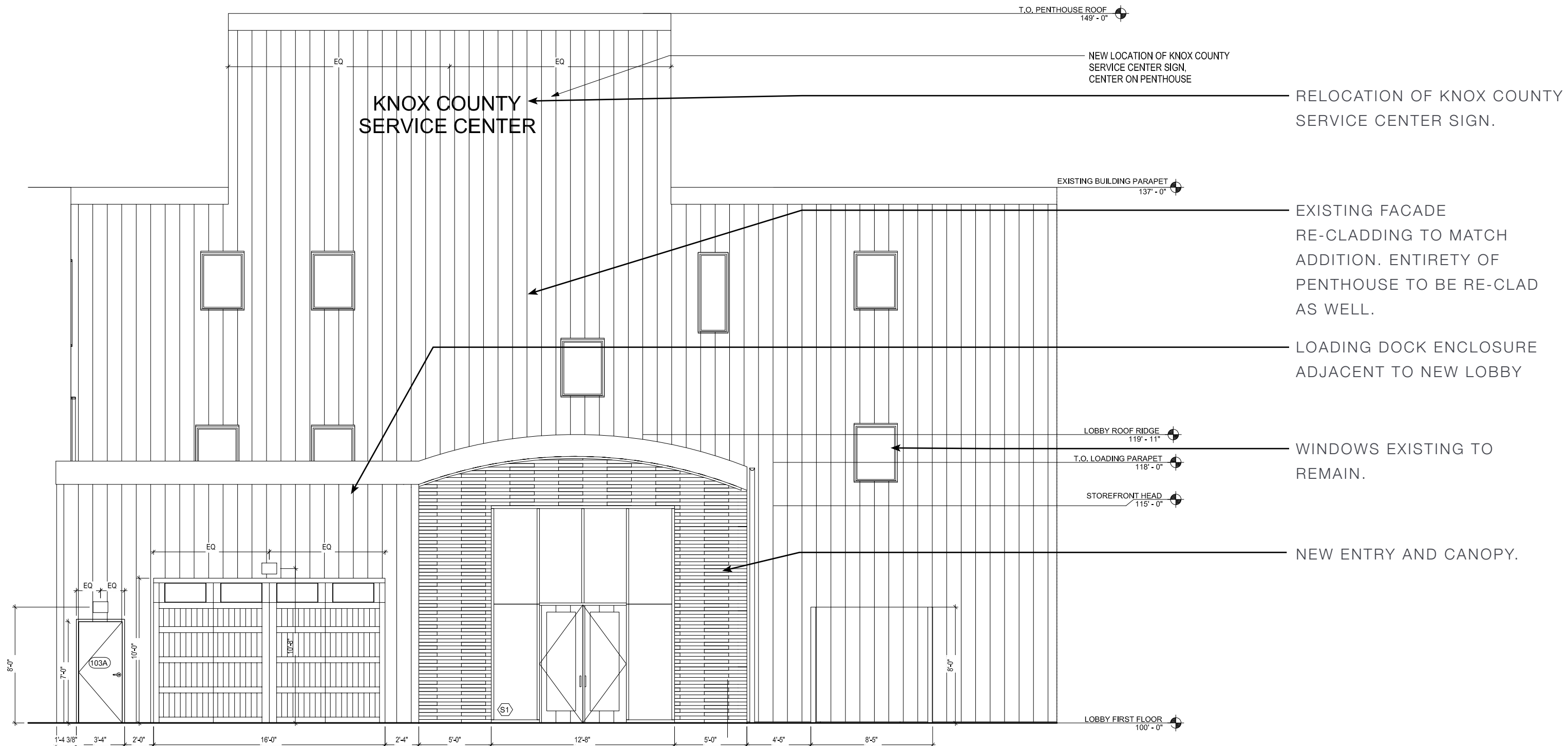

Attachment: historic\_review\_presentation\_2024.02.12 (3974 : 2024-Bza-05)

# NORTH ELEVATION

NEW BRONZE METAL PANEL

NEW ADDITION.



Attachment: historic\_review\_presentation\_2024.02.12 (3974 : 2024-Bza-05)



NORTH ELEVATION  
RENDERING





Attachment: historic\_review\_presentation\_2024.02.12 (3974 : 2024-Bza-05)



**Board of Zoning Appeals** Meeting: 03/06/24 5:30 PM  
**City of Mount Vernon Dept: Board of Zoning Appeals**  
**Mount Vernon, OH 43050**

ADOPTED Prepared By: Lacie Blankenhorn  
 Initiator: Lacie Blankenhorn

Category: N/A

**BZA FILE (ID # 3975)**

**DOC ID: 3975**

**2024-BZA-06 : 808 COSHOCTON AVE - VARIANCES FOR PARKING COUNT AND SETBACKS**

Item Number	2024-BZA-06
Site Address	808 Coshocton AVE
Parcel Number	66-07558.00
Zoning District	GB
Presented By	Lisa Latal, WT Group for Ohio FRV LLC

Quick Guide to Codified Ordinance Sections (may not be inclusive):  
 1167.03 Development Standards for Free-Standing Use on Individual Lots  
 1174.05 Required Number of Parking Spaces By Use

**Request:**

- a variance to reduce the number of required parking spaces from 13 to 10;
- a variance for side yard setbacks for pavement;
- a variance for side yard setback for an accessory structure (dumpster enclosure)

**COMMENTS - Current Meeting:**

Peck (sworn in) of Valvoline, explained their variance request for setbacks of the pavement and dumpster enclosure.

The originally requested variance for parking count is not needed due to classifying the operation as a service center and not a repair facility.

Peck explained access around the entire building is being provided to meet codes and do allow for automobile circulation. The side yard setbacks are critical to maintain the lane widths. The dumpster location is for easy access.

Percy clarified the side setbacks would be reduced from 10' to 1' 11' on one side and to 2' 7" on the other side.

Peck said there is currently just a curb that separates the neighboring O'Reilly's property from the subject parcel. On the other side there is a small strip of landscaping at the bank and a narrow gap with a pseudo curb. Peck said landscaping with sod and a couple of trees will be added to the site. It won't be all impervious.

Blankenhorn read the staff report: March 6, 2024 Case: 2024-BZA-06 808 Coshocton AVE Parcel # 66-07558.000 The subject property is zoned GB - General Business District. The proposed use is an instant oil change facility. The property is currently developed with asphalt to the property line on the west side and the primary structure is 3.3 feet from the east property line. The building has been vacant since 2014. GB Development Standards require a minimum side yard setback of 10 feet for pavement and 15 feet for structures. A variance is requested for reduced side setbacks for pavement of 1' 11" on the east side and 2' 7" on the west side. A variance is requested for a reduced side setback for a structure, the dumpster enclosure, of 2' 7" on the west side. The proposed use should be categorized as a motor vehicle service station as opposed to a motor vehicle repair station. City Code requires 2 parking spaces for each service bay of a service station. The 2 proposed bays would require 4 parking spaces. The 11 provided parking spaces, including 1 accessible space, would not require the requested variance, if the operation is categorized as a service station and not a repair station.

Simpson made a motion to accept the proposal as presented for side setbacks.

<b>RESULT:</b>	<b>ACCEPTED [UNANIMOUS]</b>
<b>MOVER:</b>	Susie Simpson, Vice-Chair
<b>SECONDER:</b>	Cynthia Cunningham, Member
<b>AYES:</b>	Percy, Simpson, Smith, Boucher, Cunningham
<b>EXCUSED:</b>	Otho Eyster, Kate Aryanata



City of Mount Vernon, Ohio  
Board of Zoning Appeals

Request for Hearing

**Applicant's Information**

Owner's Name, Address and Phone

Michael Argiros 700 PROVIDENCE HW NORWOOD, MA 02062

Agent's Name, Address and Phone

ROBIN PECK c/o Lisa Latal 100 VALVOLINE WAY LEXINGTON, KY 40509 PHONE: (937) 507-1820

**Site Information**

Site Address

808 Coshocton Ave.

Legal Description

Real property in the City of Mount Vernon, County

Parcel Number

66-07558.000

Deed Volume and Page Number

Zoning District

GB

Existing use of property

Abandon Building and Lot

Proposed use of property

Auto Service Repair - Instant Oil Change and Stati

**Hearing Request**

**Type of Hearing Requested**

Variance       Conditional Use       Appeal of Decision       Map Interpretation       Substantially Similar Use

In the following section, please list a brief description of the request. Narrative statements and any additional documents or information required by the Zoning Code and Chapter 1155 should be attached to this application as separate sheets.

Request:

We would like to request a variance to reduce the number of required parking spaces from 13 to 10. We have limited space on our site and our customers remain in their car during services they would rarely have to park and come into the building. We would also like to request a Variance for the side yard setback for pavement. We again have limited space on our site for circulation, but due to the nature of our business we need customers to be able to drive around the building. Lastly we would

I hereby certify that the information submitted on this application and on any sketches, drawings or other documents submitted with this application is true and exact.

03/13/24

Date:

By: Lisa Latal

**Status of Application**

Filing Date

Case Number

Hearing Date

Fee deposit

**\$100.00**

Date Paid

Receipt Number

Status of Board's Action

Approved       Denied

Attachment: BZA-Hearing-Application-Valvoline Mt Vernon (3975 : 2024-Bza-06)

**Narrative statements**

*establishing and substantiating that the variance conforms to the following standards:  
(initial beside the number to signify agreement; provide narrative for #3 & 4)*

LL 1) The granting of the variance shall be in accord with the general purpose and intent of the regulations imposed by this Zoning Ordinance on the district in which it is located, and shall not be injurious to the area or otherwise detrimental to the public welfare.

LL 2) The granting of the variance will not permit the establishment of any use which is not otherwise permitted in the district.

3) Describe the special circumstances or conditions, applicable to the land or buildings for which the variance is sought, which are peculiar to such land or buildings and do not apply generally to land or buildings in the area, and which are such that the strict application of the provisions of this Zoning Ordinance would deprive the applicant of the reasonable use of such land or building. There must be deprivation of beneficial use of land.

We would like to request a parking variance to reduce the number of required parking spaces from 12 plus 1 HC space to 10 plus one HC space.

We would also like to request a setback for pavement variance from 10' on the east to 1'-11", from 10'-0" to 2'-7" on the West side, and a setback for the parking space on the southeast side from 10'-0" to 7'-4"

Lastly we would like to request a building setback variance for our trash enclosure to be in the side yard setback from 15'-0" to 2'-7".

4) Explain the proof of hardship created by the strict application of this Zoning Ordinance.

**Parking Variance**

Due to the function of our business our customers remain in their car, therefore the majority of parking spaces are required for our employees.

**Pavement Setback**

Upon inspection neighboring properties have pavement to the lot line. This is due to the nature of the business and the narrowness of the lots. Therefore Valvoline is a automobile type of use therefore to allow for safe circulation of the lot due to the nature of our business and the width of the lot.

**Building Setback**

The proper circulation of the trash vehicle mandates the placement of the trash enclosure and hence the request for the variance.

LL 5) The granting of the variance is necessary for the reasonable use of the land or building, and the variance as granted is the minimum variance that will accomplish this purpose.

LL 6) The proposed variance will not impair an adequate supply of light and air to adjacent property, substantially increase the congestion in the public streets, increase the danger of fire, endanger the public safety, or substantially diminish or impair property values of the adjacent area.

LL 7) The granting of the variance requested will not confer on the applicant any special privilege that is denied by this regulation to other lands, structures, or buildings in the same district.

Attachment: BZA-Hearing-Application-Valvoline Mt Vernon (3975 : 2024-Bza-06)

Supplement to Application and Narrative Statement forms:

**Application Request Field:**

We would like to request a variance to reduce the number of required parking spaces from 13 to 10. We have limited space on our site and our customers remain in their car during services they would rarely have to park and come into the building. We would also like to request a Variance for the side yard setback for pavement. We again have limited space on our site for circulation, but due to the nature of our business we need customers to be able to drive around the building. Lastly we would like to request a variance for our trash enclosure to be in the side yard setback. The location we have chosen seems to be the best for the trash company to pick up and be able to drive out of our site.

**Narrative Statement #4**

**Parking Variance**

Due to the function of our business our customers remain in their car, therefore the majority of parking spaces are required for our employees.

**Pavement Setback**

Upon inspection neighboring properties have pavement to the lot line. This is due to the nature of the business and the narrowness of the lots. Therefore Valvoline is a automobile type of use therefore to allow for safe circulation of the lot due to the nature of our business and the width of the lot.

**Building Setback**

The proper circulation of the trash vehicle mandates the placement of the trash enclosure and hence the request for the variance.

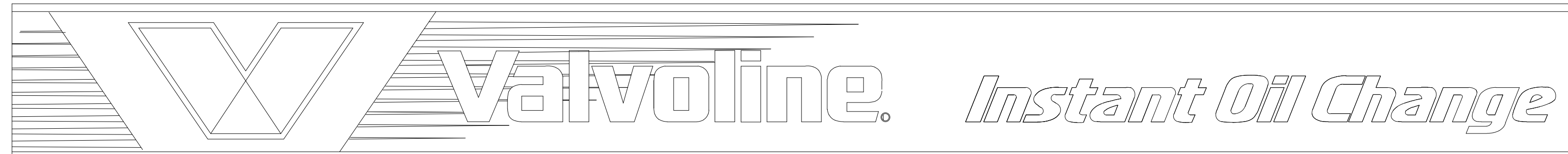

808 COSHOCTON AVE. MT. VERNON, OH 43050

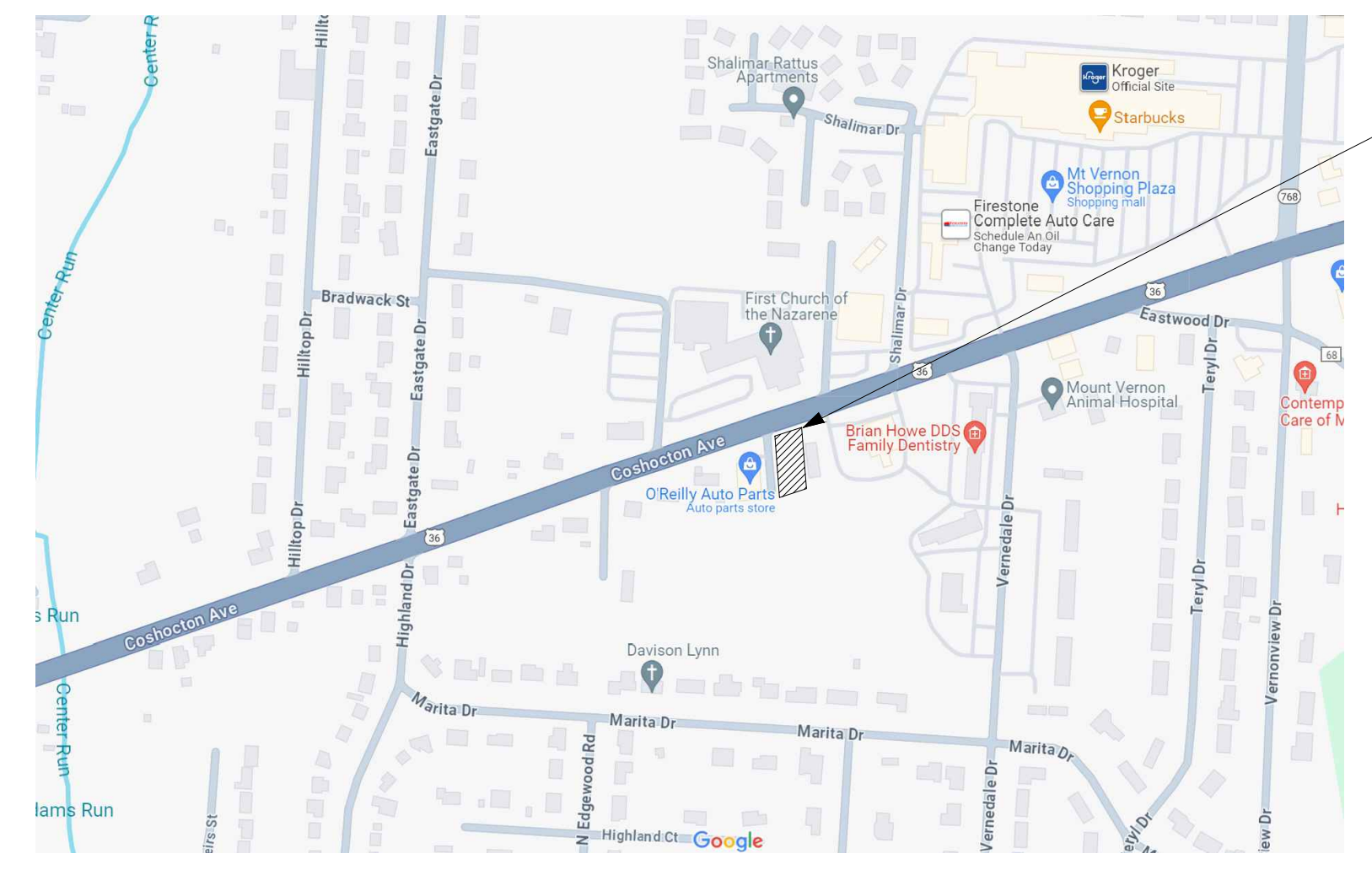

SITE

DRAWING INDEX AND ISSUANCE LOG		ISSUE	DATE	SHEET #	SHEET NAME
GENERAL	COVER SHEET	•	02/14/2024		
ARCHITECTURAL	ARCHITECTURAL SITE PLAN	•			
A-1.0	EXTERIOR RENDERINGS	•			
A-3.1	EXTERIOR ELEVATIONS	•			
A-10.1	DUMPSTER ENCLOSURE	•			
C-8	PHOTOMETRIC PLAN	•			
LP-1	LANDSCAPE PLAN	•			
LP-2	LANDSCAPE DETAILS AND SPECIFICATIONS	•			
1	ALTA SURVEY	•			

RYAN R. TRIPPAHN DESIGN, PLLC  
 CONTACT: RYAN R. TRIPPAHN  
 2675 PRATUM AVENUE, SUITE 200  
 HOFFMAN ESTATES, IL 60192  
 PH: 847-452-7278  
 EMAIL: RTRIPPAHN@GMAIL.COM

**COPYRIGHT NOTICE**  
 This drawing is the property of the above referenced Professional and is not to be used for any purpose other than the specific project and site names herein, and cannot be reproduced in any manner without the express written permission from the Professional.

DATE	ISSUE
01/31/2024	OWNER REVIEW SET
02/14/2024	SITE PLAN REVIEW

PROFESSIONAL SEAL

PROFESSIONAL LICENSE NO:  
 ARC 591747  
 CERTIFICATE OF AUTHORIZATION NO:  
 FRM 2134408

PROFESSIONAL IN CHARGE  
 RYAN R. TRIPPAHN

PROJECT MANAGER  
 AG

QUALITY CONTROL  
 JL, JG

PROJECT NAME



**VALVOLINE INSTANT OIL CHANGE**  
 808 COSHOCTON AVE.  
 MT. VERNON, OH 43050

PROJECT NUMBER  
 D2300135

SHEET NAME

COVER SHEET

SHEET #

CS-1

ABBREVIATIONS

AL. ALUMINUM	EA. EACH	G.G. GENERAL CONTRACTOR	OA. OVERALL	SPK. SPEAKER
A.F.F. ABOVE FINISHED FLOOR	ELEC. ELECTRICAL	GW.B. GYPSUM WALL BOARD	OD. OUTSIDE DIAMETER	SQ. SQUARE
BD. BOARD	EL. ELEVATION	HC. HANDICAPPED	OPNG. OPENING	S.S. STAINLESS STEEL
B.D.G. BUILDING BLOCKING	EMER. EMERGENCY	HM. HORIZONTAL	OPP. OPPOSITE	STL. STEEL
BLKG. BEARING	EQUIP. EQUIPMENT	HORIZ. HORIZONTAL	ON CENTER	STOR. STORAGE
BRG. BEARING	EQ. EXISTING	ID. INSIDE DIAMETER	PLAM. PLASTIC LAMINATE	SUPP. SUPPLIER
CAB. CABINET	EXP. EXPANSION	INST. INSTALLER	PAIR. PAIR	SUSP. SUSPENDED
CL.G. CEILING	EXT. EXTERIOR	INSUL. INSULATION	PAINT. PAINT	TEL. TELEPHONE
CMU. CONCRETE MASONRY UNIT	E.J. EXPANSION JOINT	INT. INTERIOR	PRES. PRESSURE TREATED	TEN. TENANT / OWNER / FRANCHISEE
COL. COLUMN	FA. FIRE ALARM	JT. JOINT	PLYWOOD	TYP. TYPICAL
CON. CONTRACTOR	FD. FLOOR DRAIN	LAM. LAMINATE	QT. QUARRY TILE	T.C.C. TENANTS CABINET CONTRACTOR
CONC. CONCRETE	FE. FIRE EXTINGUISHER	LAV. LAVATORY	RA. RETURN AIR	T.E.C. TENANTS ELECTRICAL CONTRACTOR
CONST. CONSTRUCTION	FIN. FINISHED	LL. LANDLORD	RE. REFERENCE / REFER TO	T.G.C. TENANTS GENERAL CONTRACTOR
CONT. CONTINUOUS OR CONTINUE	FLR. FLOOR(ING)	MATL. MATERIAL	RD. ROOF DRAIN	U.O.N. UNLESS OTHERWISE NOTED
CPT. CARPET(ED)	FOC. FACE OF CONCRETE	MAX. MAXIMUM	REFR. REFRIGERATOR	VCT. VINYL COMPOSITION TILE
CTR. COUNTER	FOF. FACE OF FINISH	MDF. MEDIUM DENSITY FIBER BOARD	REIN. REINFORCE (D) (ING)	VERT. VERTICAL
CT. CERAMIC TILE	FOM. FACE OF MASONRY	MECH. MECHANICAL	REQM.TS. REQUIREMENTS	VT. VINYL TILE
C.J. CONTROL JOINT	FOS. FACE OF STUD	MFG. MANUFACTURER	REQ. REQUIRED	V.I.F. VERIFY IN FIELD
C.O. CASSED OPENING	FRP. FIBERGLASS REINFORCED PANEL	MIN. MINIMUM	RES. RESILIENT	WC. WATER CLOSET
DIA. DIAMETER	FTG. FOOTING	MISC. MISCELLANEOUS	R.O. ROUGH OPENING	WD. WOOD
DIM. DIMENSION	FT. FOOT OR FEET	M.O. MASONRY OPENING	SCH. SCHEDULE	WWF. WELDED WIRE FABRIC
DISP. DISPENSER	FURR. FURRED (ING)	MTL. METAL	SC. SECTION	W. WITH
DIV. DIVISION	F.R. FIRE RESISTANT	N.I.C. NOT IN CONTRACT	SEC. SECTION	W/O. WITHOUT
DR. DOOR	GALV. GALVANIZED	NOM. NOMINAL	SHTG. SHEATHING	
DSL. DOWNSPOUT	GA. GAUGE	NTS. NOT TO SCALE	SH. SHELF	
DTL. DETAIL	GD. GRADE OR GRADING		SIL. SIMILAR	
DWG. DRAWING	GL. GLASS		SPEC. SPECIFICATION	
DWR. DRAWER	GYP. GYPSUM			

PROJECT DIRECTORY

<b>PRE-CONSTRUCTION P.M.</b> Valvoline Instant Oil Change Robin Beck 100 Valvoline Way Lexington, KY 40509 Bus: (937) 507-1820	<b>ARCHITECT</b> RYAN R. TRIPPAHN, PLLC Ryan R. Trippahn 2675 Pratum Avenue Hoffman Estates, IL 60192 Bus: (847) 452-7278	<b>CIVIL ENGINEER</b> WT Group Todd Abrams 2675 Pratum Avenue Hoffman Estates, IL 60192 Bus: (224) 293-6333
<b>CONSTRUCTION P.M.</b> Valvoline Instant Oil Change Jacob Eisenhauser 100 Valvoline Way Lexington, KY 40509 Bus: (585) 333-9604	<b>STRUCTURAL ENGINEER</b> WT Group Christopher Starke 2675 Pratum Avenue Hoffman Estates, IL 60192 Bus: (224) 293-6333	<b>MEP ENGINEERS</b> WT Group Mark Ventrelli 2675 Pratum Avenue Hoffman Estates, IL 60192 Bus: (224) 293-6333
<b>LANDSCAPE ARCHITECT</b> Evergreen Design Group Sharon Stachecki 100 E. Campus View Blvd. Suite 250 Columbus, OH 43235 Bus: (600) 880-6630	<b>LUBE EQUIP. SUPPLIER</b> Devon Industries, Inc. Brian Stoops P.O. Box 270514 Oklahoma City, OK 73137 Bus: (405) 868-6665	

DRAWING SYMBOL KEY

<b>(D#)</b> DOOR NUMBER (SEE DOOR SCHEDULE)	<b>(#)</b> FIXTURE/EQUIPMENT TAG (SEE FIXTURE AND EQUIPMENT SCHEDULE)	<b>(ITEM DENOTED)</b> (ELEVATION OF ITEM)	ELEVATION MARK
<b>X</b> STOREFRONT TAG (SEE STOREFRONT OPENING SCHEDULE)	<b>#</b> KEY NOTE	<b>#</b> DETAIL #	DETAIL SECTION
<b>X-#</b> FINISH TAG (SEE FINISH SCHEDULE)	<b>#</b> REVISION TAG (SEE PROJECT TRACKING)	<b>#</b> SHEET #	BUILDING AND WALL SECTION
	<b>#</b> REVISION CLOUD (DENOTES AREA OR ITEM ON DRAWING AFFECTED BY REVISION)	<b>#</b> SHEET #	INTERIOR ELEVATION TAGS

PRODUCT SUBMITTALS

DIVISION 03 - CONCRETE	CONCRETE REINFORCEMENT	(REQUIRED)
03200	CAST-IN-PLACE CONCRETE	
DIVISION 04 - MASONRY		(NOT REQUIRED - AS SPECIFIED)
DIVISION 05 - METALS	STRUCTURAL STEEL	(REQUIRED)
05120	STEEL JOISTS	(WHERE OCCURS)
05210	STEEL DECK	
05310	METAL FABRICATIONS	
05500	MISCELLANEOUS METAL WORK	
DIVISION 06 - WOOD AND PLASTICS	OPEN WEB TRUSSES	(REQUIRED)
06175		
DIVISION 07 - THERMAL AND MOISTURE PROTECTION		(NOT REQUIRED - AS SPECIFIED)
DIVISION 08 - OPENINGS		(NOT REQUIRED - AS SPECIFIED)
DIVISION 09 - FINISHES		(NOT REQUIRED - AS SPECIFIED)
DIVISION 10 - SPECIALTIES		(NOT REQUIRED - AS SPECIFIED)
DIVISION 11 - EQUIPMENT		(NOT REQUIRED - AS SPECIFIED)
DIVISION 22 - PLUMBING		(NOT REQUIRED - AS SPECIFIED)
DIVISION 23 - HVAC		(NOT REQUIRED - AS SPECIFIED)
DIVISION 26 - ELECTRICAL		(NOT REQUIRED - AS SPECIFIED)
DIVISION 27 - COMMUNICATIONS		(NOT REQUIRED - AS SPECIFIED)
DIVISION 31 - EARTHWORK		(NOT REQUIRED - AS SPECIFIED)
DIVISION 32 - IMPROVEMENTS		(NOT REQUIRED - AS SPECIFIED)
DIVISION 33 - UTILITIES		(NOT REQUIRED - AS SPECIFIED)

SPECIAL PHOTOGRAPHIC REQ.

THE FOLLOWING IS A LIST OF PHOTOGRAPHS THAT SHALL BE TAKEN BY THE GENERAL CONTRACTOR DURING THE COURSE OF CONSTRUCTION. THESE PHOTOS SHALL BE TAKEN AT APPROPRIATE INTERVALS AND SHALL BE DELIVERED TO VIOC CONSTRUCTION REPRESENTATIVES ON A WEEKLY BASIS AND SHALL BE TRANSMITTED ELECTRONICALLY VIA E-MAIL. THE PURPOSE OF THESE PHOTOGRAPHS IS TO DOCUMENT CONSTRUCTION, DISTRIBUTION AND/OR REVIEW OF SUCH PHOTOS BY THE OWNER SHALL NOT IN ANY WAY BE MISCONSTRUED AS ACCEPTANCE OF COMPLETED WORK AND DOES NOT RELIEVE THE CONTRACTOR OF HIS RESPONSIBILITY TO COMPLY FULLY WITH THE REQUIREMENTS SET FORTH IN THE CONTRACT DOCUMENTS. FAILURE TO TAKE THESE PHOTOGRAPHS OR FOLLOW THESE PROCEDURES MAY RESULT IN REMOVAL OF IN-PLACE WORK, PHOTOGRAPHIC DOCUMENTATION, AND REPLACEMENT OF WORK AT THE SOLE EXPENSE OF THE GENERAL CONTRACTOR WITHOUT DETRIMENTALLY IMPACTING THE SCHEDULED DATE FOR COMPLETION.

**GENERAL WEEKLY PHOTOS**

- OVERALL SITE PHOTOS FROM SEVERAL CONSISTENT VANTAGE POINTS
- PHOTOS IN EACH ROOM FROM OPPOSITE SIDES OF EACH ROOM
- DETAILED PHOTOS OF ISSUES TO BE RESOLVED
- DETAILED PHOTOS OF WORK ACCOMPLISHED IN THE PAST WEEK

**SPECIFIC DETAIL PHOTOS**

- SITE UTILITIES PRIOR TO BACKFILLING
- ALL DOUBLE CLEANOUTS INCLUDING AREA SHOTS TO INDICATED LOCATIONS
- ALL TRENCHES DURING THE BACKFILL PROCESS
- ALL ASPHALT BASE, BASE COURSE, AND TOP COURSE THICKNESS
- ALL PAVING, FOUNDATION, AND SLAB POURS JUST PRIOR TO CONCRETE PLACEMENT
- PAVING, FOUNDATION, AND SLAB STEEL PLACEMENT IN VARIOUS LOCATIONS AROUND THE BUILDING
- UNDER SLAB WATERPROOFING & VAPOR BARRIER INSTALLATIONS
- FOUNDATION WATERPROOFING FROM FOOTING TO TOP OF FLOOR
- LIGHT POLE BASES PRIOR TO CONCRETE PLACEMENT INCLUDING STEEL AND BOLTS
- UNDERGROUND PLUMBING INSIDE THE BUILDING
- SUMPS IN PLACE PRIOR TO BACKFILL INCLUDING CONNECTIONS
- BACK FILL PROCESS FOR SUMPS
- GLASS INSTALLATION DETAILS AT ALL STAGES INCLUDING:
  - FLASHING UNDER SILL RECEPTOR, SILL RECEPTOR IN PLACE, END DAMS SEALED ON SILL RECEPTOR, LAPS (IF REQUIRED) IN SILL RECEPTOR, SHIMS (UNDER SILL), PROPER JAMB AND HEAD GAPS
- ALL WALLS PRIOR TO SHEETROCK INSTALLATION SHOWING ALL BLOCKING, PLUMBING, STRUCTURAL CONNECTS AT BOTTOM AND TOP PLATES, WALL ANCHORS, ELECTRICAL CONDUIT, AND INSULATION AT A MINIMUM
- RESTROOM PRIOR TO FINISHES TO SHOW WALLBOARD AND TILE BACKER
- PAINT BUCKETS INDICATING MANUFACTURER AND PAINT TYPE SHOWN ON JOB SITE.

GENERAL NOTES

- THESE NOTES SHALL APPLY UNLESS OTHERWISE INDICATED BY DRAWINGS OR SPECIFICATIONS.
- ALL WORK SHALL BE PERFORMED IN STRICT COMPLIANCE WITH ALL APPLICABLE FEDERAL, STATE, & LOCAL CODE REQUIREMENTS, AND IN ACCORDANCE WITH ACCEPTED CONSTRUCTION INDUSTRY STANDARDS.
- OWNER SHALL OBTAIN & PAY FOR BUILDING & SIGN PERMITS. CONTRACTOR SHALL OBTAIN AND PAY FOR ALL OTHER APPLICABLE PERMITS, INSPECTIONS AND APPROVALS.
- PRIOR TO TURNING BUILDING OVER TO OWNER, REPAIR/REPLACE ALL MATERIALS, GLASS, OR ASSEMBLIES DAMAGED OR BROKEN DURING CONSTRUCTION.
- SMOKE DETECTORS SHALL BE HARDWIRED INTO AN AC ELECTRICAL. POWER SOURCE AND SHALL BE EQUIPPED WITH BATTERY BACK-UP. SMOKE DETECTORS SHALL BE TESTED FOR COMPLIANCE UPON COMPLETION OF WORK.
- SEAL ALL PENETRATIONS THRU FLOOR DECK. ALSO REFER TO STRUCTURAL PENETRATION PLAN FOR LOCATIONS.
- FRAMER SHALL PROVIDE IN-WALL BLOCKING AS REQUIRED AT TOILET ACCESSORIES, CABINETS, COUNTERTOPS & ALL AREAS w/ WALL HUNG ITEMS OR AS ALSO CALLED OUT IN THESE DOCUMENTS.
- FRAMER SHALL PROVIDE 2x FIRE BLOCKING @ ALL CONCEALED SPACES OF ALL STUD WALLS @ CEILING LEVEL AND @ 10' INTERVALS AND/OR AS OTHERWISE REQUIRED BY CODE.
- PROVIDE KNOX-BOX IN ACCORDANCE W/ FIRE DEPARTMENT REQUIREMENTS.
- ALL CONCRETE SLAB TO BUILDING JOINTS ARE TO BE PROVIDED WITH SEALANT AND BACKER ROD.
- DIMENSIONS NOTED ON PLANS ARE TO THE OUTSIDE FACE OF WD. STUD FRAMING UNLESS NOTED OTHERWISE.
- GENERAL CONTRACTOR SHALL PROVIDE ALL TEMPORARY UTILITIES NECESSARY/REQUIRED UNTIL PROJECT COMPLETION.

### LEGAL DESCRIPTION

#### VALVOLINE PARCEL DESCRIPTION

Real property in the City of Mount Vernon, County of Knox, State of Ohio, and being a part of Lot Numbers eleven (#11) and twelve (#12) in Highland Park of record in Plat Book 3, Pages 90 and 91, Recorder's Office Knox County Ohio, and beginning at an Iron Pin in the Northwest corner of said Lot Number 11 Highland Park and the southerly right-of-way of Coshocton Avenue (60 feet in width) said point being the northwesterly corner thereof;

Thence with said southerly right of way line of Coshocton Avenue, North 71°22'25" East, a distance of 115.00 feet to a set Iron Pin, and being the **True Point of Beginning**;

Thence continuing with said right of way line of Coshocton Avenue, the following courses:

- North 71°22'25" East, a distance of 84.59 feet to a set Iron Pin;
- South 09°06'40" East, a distance of 5.81 feet to a found 5/8 inch Iron Pin stamped "ODOT ROW";
- North 71°08'43" East, a distance of 29.97 feet to a found 5/8 inch Iron Pin stamped "ODOT ROW" at the northwest corner of a tract conveyed to First Knox National Bank, as recorded in Book 1299, Pages 663-668;

Thence with the westerly line of said First Knox National Bank, South 05°46'13" East, a distance of 214.25 feet to a set Iron Pin;

Thence with the northerly line of a tract in the name of First Knox National Bank, South 71°22'25" West, a distance of 114.88 feet to a point in the westerly line of a tract conveyed to O'Reilly Auto Enterprises, LLC., as recorded in Book 1456, Pages 779-781 and referenced by a found 1 inch Iron Pin at North 05°46'13" West, a distance of 0.65 feet;

Thence with the westerly line of said O'Reilly Auto Enterprises, LLC., North 05°46'13" West, a distance of 220.00 feet to the **True POINT OF BEGINNING**.

Containing **0.562 Acres**, and being subject to all covenants, restrictions, reservations and easements contained in any instrument of record pertaining to the above described tract of land.



1 KEY PLAN  
A-1.0 Scale: N.T.S.

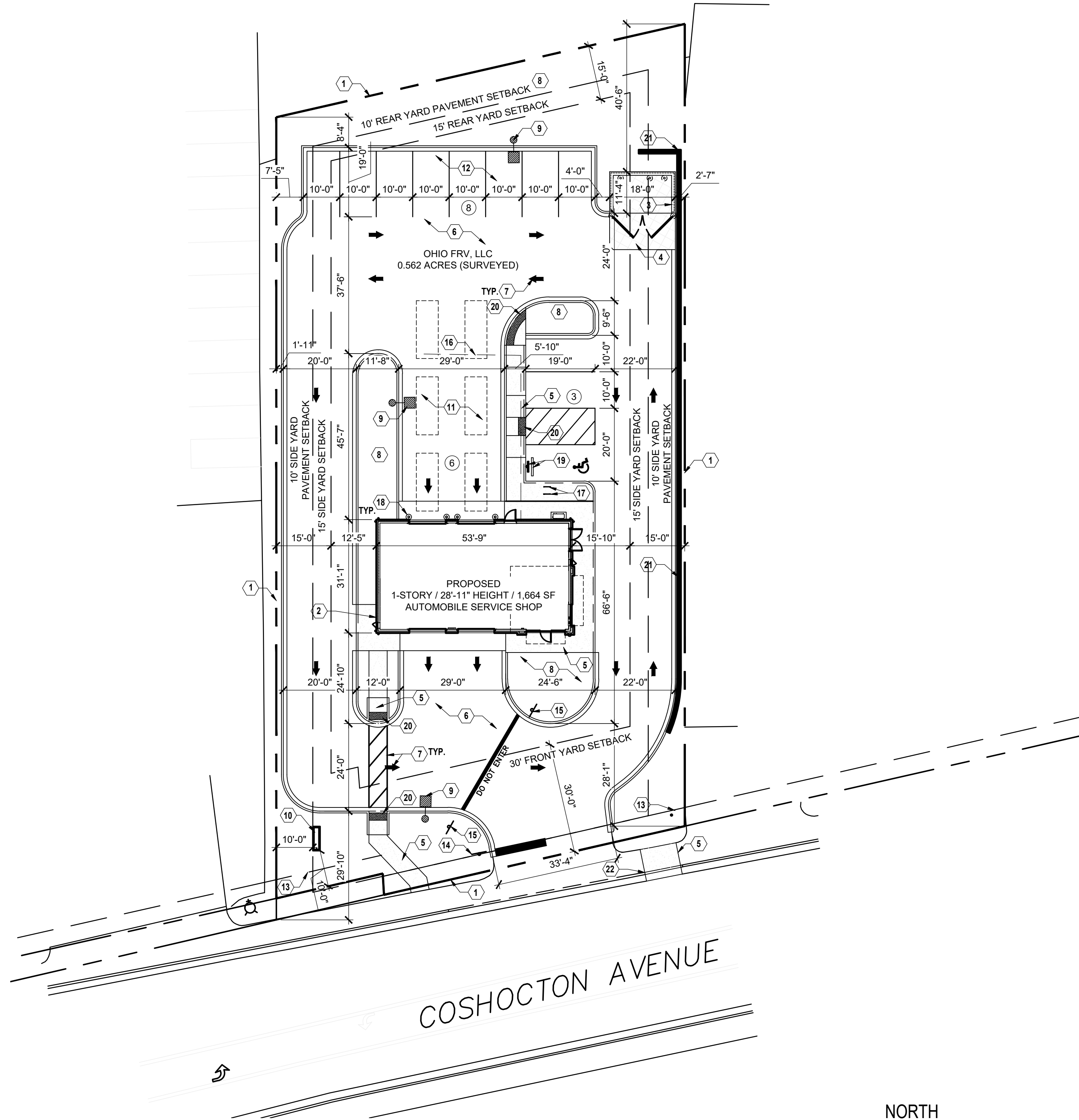

2 ARCHITECTURAL SITE PLAN  
A-1.0 Scale: 1" = 20'-0"



### CONTACTS

PROPERTY OWNER:  
OHIO FRV LLC  
700 PROVIDENCE HW  
NORWOOD, MA 02062

APPLICANT / TENANT:  
VALVOLINE INSTANT OIL CHANGE  
100 VALVOLINE WAY  
LEXINGTON, KY 40509  
CONTACT: ROBIN PECK  
PHONE: (937) 507-1820

### PROPERTY INFORMATION

BUILDING ADDRESS:  
808 COSHOCTON AVE.  
MT. VERNON, OH 43050

PARCEL NUMBER 6607558000  
LOT AREA +/- 24,669 S.F.  
F.A.R. 1.15  
LOT COVERAGE 0.042 (1,850 SF)

PROPOSED PERVIOUS COVER: 6,141 S.F. (33%)  
PROPOSED IMPERVIOUS COVER: 17,206 S.F. (67%)

EXISTING ZONING: GB, GENERAL BUSINESS  
PROPOSED ZONING: GB, GENERAL BUSINESS  
ADJACENT ZONING: GB, ALL SIDES  
PERMITTED USED: AUTOMOTIVE SERVICES AND REPAIR / GARAGE;  
ALL OPERATIONS WITHIN BUILDING

SETBACKS:  
FRONT YARD SETBACK = 30 FEET  
SIDE YARD SETBACK = 15 FEET  
REAR YARD SETBACK = 15 FEET

### BUILDING INFORMATION

**USE STATEMENT:** AN EXISTING BUILDING ON THE PROPERTY WILL BE DEMOLISHED. APPLICANT INTENDS TO CONSTRUCT A NEW COMMERCIAL RETAIL AUTOMOBILE REPAIR BUILDING ON THE PROPERTY WITH AN ADJOINING PAVED LOT FOR OFF-STREET PARKING. TENANT'S PRIMARY RETAIL SERVICE IS AUTOMOTIVE OIL CHANGES. TENANT INTENDS TO COMPLETE THEIR DEVELOPMENT AS A PHASE DEVELOPMENT TO INCLUDE A MASONRY DUMPSTER ENCLOSURE LOCATED IN THE REAR OF THE PROPERTY.

HEIGHT: 28'-11", 1-STORY WITH FULL BASEMENT (35'-0" MAX ALLOWABLE)  
WIDTH: 53'-9"  
DEPTH: 31'-11"  
GROSS AREA: 2,989 S.F.  
BASEMENT: 1,498 S.F.  
GROUND FLOOR: 1,491 S.F.

NO. SERVICE BAYS: 2  
NO. EMPLOYEES: 8 (4 EMPLOYEES PER SERVICE BAY)

### PARKING CALCULATIONS

PARKING CALCULATIONS BASED ON GROSS BUILDING AREA OF 1,664 S.F.

REQUIRED PARKING:  
1 STALL PER 400 S.F. OF BUILDING  
1,664 S.F. / 400 = 5 STALLS  
1 STALL PER EMPLOYEE  
X 8 EMPLOYEES = 8 STALLS  
TOTAL: 13 STALLS

1 ADA STALL PER 25  
13 / 25 = 1 STALL  
TOTAL: 13 STALLS

REQUIRED STACKING:  
3 STACKING STALLS PER BAY  
X 2 BAYS  
6 STACKING  
PROVIDED STACKING:  
(6) STACKING STALLS

REQUIRED BICYCLE PARKING:  
N/A  
PROVIDED BICYCLE PARKING: 2

### SITE KEYNOTES

- PROPERTY LINE
- PROPOSED 1-STORY COMMERCIAL RETAIL BUILDING, SEE SHEET A-1-1
- MASONRY DUMPSTER ENCLOSURE W/ CONCRETE PAD, SEE SHEET A-1-1
- CONCRETE PAD IN FRONT OF DUMPSTER ENCLOSURE
- CONCRETE WALK
- ASPHALT PAVING
- PAVEMENT STRIPING & NAVIGATION SYMBOLS
- LANDSCAPING, PER LANDSCAPE ARCHITECT. SEE LANDSCAPING PLANS
- POLE MOUNTED SITE LIGHTING, SEE PHOTOMETRIC PLAN
- MONUMENT SIGN
- STACKING PARKING FOR SERVICE BAYS
- OFF-STREET PARKING FOR PATRONS AND EMPLOYEES
- UTILITY EASEMENTS, SEE SURVEY
- STOP SIGN & STOP BAR
- DO NOT ENTER SIGN
- SERVICE BELL HOSE
- BIKE RACK
- PIPE BOLLARD (SEE PLANS FOR QUANTITY/LOCATION). REFER TO DETAIL 6/A-10.1.
- HANDICAPPED PARKING SIGN AND BUMPER STOP
- ADA DETECTABLE WARNING PAD
- RETAINING WALL
- NEW CURB

RYAN R. TRIPHAHN DESIGN, PLLC  
CONTACT: RYAN R. TRIPHAHN  
2635 PRATIUM AVENUE SUITE 200  
HOFFMAN ESTATES, IL 60192  
PH: 847.452.2778  
EMAIL: RTRIPHANDESIGN@GMAIL.COM

**COPYRIGHT NOTICE**  
This drawing is the property of the above referenced Professional and is not to be used for any purpose other than the specific project and site names herein, and cannot be reproduced in any manner without the express written permission from the Professional.

DATE	ISSUE
01/31/2024	OWNER REVIEW SET
02/14/2024	SITE PLAN REVIEW

PROFESSIONAL SEAL

PROFESSIONAL LICENSE NO:  
ARC1917747  
CERTIFICATE OF AUTHORIZATION NO:  
FIRM 21314408

PROFESSIONAL IN CHARGE  
RYAN R. TRIPHAHN

PROJECT MANAGER  
AG

QUALITY CONTROL  
JL

DRAWN BY  
JL, JG

PROJECT NAME



**VALVOLINE INSTANT OIL CHANGE**  
808 COSHOCTON AVE.  
MT. VERNON, OH 43050

PROJECT NUMBER  
D23000135

SHEET NAME  
**ARCHITECTURAL - SITE PLAN**

SHEET #

**A-1.0**

ISSUE RECORD  
DATE 02/14/2024  
SITE PLAN REVIEW

808 COSHOCTON AVE.  
WEST OF VERNEDALE DRIVE.  
MT VERNON OH 43050  
Attachment: site\_plan\_review\_20240213 (3975 : 2024-Bza-06)



2 OVERALL RIGHT SIDE EXTERIOR ELEVATION (RIGHT)  
Scale: 1/8" = 1'-0"



1 OVERALL BACK EXTERIOR ELEVATION  
Scale: 1/8" = 1'-0"

T.O. ROOF ± 28' - 11"  
T.O. ROOF ± 22' - 7"  
B.O. SOFFIT 13' - 5 3/4"  
T.O. WAINSCOT 4' - 0"  
UPPER LEVEL 0' - 0"



4 OVERALL LEFT SIDE EXTERIOR ELEVATION (LEFT)  
Scale: 1/8" = 1'-0"



3 OVERALL FRONT EXTERIOR ELEVATION  
Scale: 1/8" = 1'-0"

T.O. ROOF ± 28' - 11"  
B.O. SOFFIT 23' - 4 3/4"  
B.O. SOFFIT 13' - 5 3/4"  
T.O. WAINSCOT 4' - 0"  
UPPER LEVEL 0' - 0"

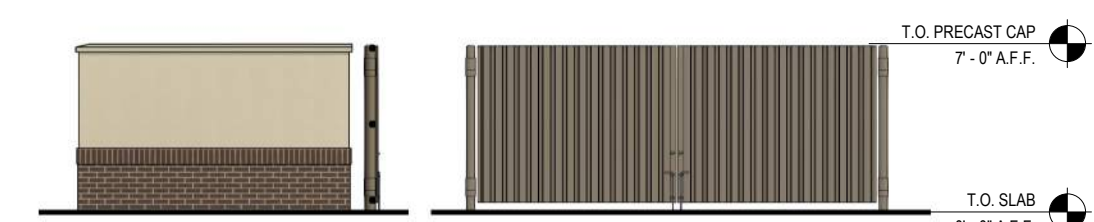

5 OVERALL FRONT & SIDE TRASH ENCLOSURE ELEVATIONS  
Scale: 1/8" = 1'-0"

T.O. PRECAST CAP 7' - 0" A.F.F.  
T.O. SLAB 0' - 0" A.F.F.

**EXTERIOR FINISHES - BRICK / EIFS**

EXTERIOR INSULATED FINISH SYSTEM:	DRYVIT (SANDPEBBLE FINE) COLOR: E.I.F.S. 1 = #113 AMARILLO WHITE	STANDING SEAM AWNING:	FIRESTONE UNA-CLAD KYNAR 500 / HYLAR METAL 5000 FLUOROCARBON STEEL "CHAMPAGNE METALLIC", UNDERSIDE & FRAME TO BE PAINTED SW 6152 "SUPERIOR BRONZE"	STOREFRONT SYSTEM:	2x4 1/2" KAWNEER TRIFAB VG 451T SERIES CLEAR ANODIZED ALUMINUM STOREFRONT SYSTEM w/ 1" INSULATED GLAZING.
FACE BRICK : (WAINSCOT)	BELDEN - "MODULAR MIDLAND BLEND"	ROOF SHINGLES:	OWENS CORNING DURATION SERIES "DRIFTWOOD"	H.M. DOORS & FRAMES:	FIELD PAINT SHERWIN-WILLIAMS SW-7515 "HOMESTEAD BROWN". PROVIDE MOCK-UP AND VERIFY COLOR W/OWNER.
PRECAST CAP :	CUSTOM CAST STONE - "LIGHT BUFF"	MISC. ROOF VENTS, FANS, ETC.	FIELD PAINT SHERWIN-WILLIAMS SW7046 "ANONYMOUS"	O.H. DOOR FINISH:	CLEAR ANODIZED ALUMINUM
MORTAR:	LEHIGH STANDARD KIT - "BEIGE"	GUTTER, DOWNSPOUTS, FASCIA, EXTERIOR SOFFIT, & EXPOSED TRIM	DIMENSIONAL METALS, INC. - "BEIGE"		
MASONRY SEALER:	ALL MASONRY SURFACES SHALL BE TREATED w/ SEALER.				

11/13/2023 11:33:47 AM \\192.168.100.22\CDDG\2023 PROJECTS\2300135 - Valvoline - Mount Vernon, OH - Coshocton Avenue\100 CURRNT\2BRH-STND Arch.rvt

RYAN R. TRIPPAHN DESIGN, PLLC  
 CONTACT: RYAN R. TRIPPAHN  
 2635 PRATTMAN AVENUE, SUITE 200  
 HOFFMAN ESTATES, IL 60192  
 PH: 847.452.7278  
 EMAIL: RTRIPPAHN@GMAIL.COM

**COPYRIGHT NOTICE**  
 This drawing is the property of the above referenced Professional and is not to be used for any purpose other than the specific project and site names herein, and cannot be reproduced in any manner without the express written permission from the Professional.

DATE	ISSUE
07/31/2024	OWNER REVIEW SET
02/14/2024	SITE PLAN REVIEW

PROFESSIONAL SEAL

PROFESSIONAL LICENSE NO.  
 ARC1917747  
 CERTIFICATE OF AUTHORIZATION NO.  
 FRM 21314408

PROFESSIONAL IN CHARGE  
 RYAN R. TRIPPAHN  
 PROJECT MANAGER  
 AG  
 QUALITY CONTROL  
 JL  
 DRAWN BY  
 JL, JG

PROJECT NAME



**VALVOLINE INSTANT OIL CHANGE**  
 808 COSHOCTON AVE.  
 MT. VERNON, OH 43050

PROJECT NUMBER  
 123000135

SHEET NAME  
**EXTERIOR ELEVATIONS**

SHEET #

**A-3.1**

**ELEVATION NOTES**

- EIFS SHALL BE DRYVIT, CLASS PB DRAINAGE SYSTEM WITH FLUID APPLIED WATER RESISTIVE BARRIER BEHIND INSULATION BOARD.
- SIGNAGE SHOWN ON THESE ELEVATIONS IS FOR GENERAL REFERENCE PURPOSES ONLY. ALL SIGNAGE SHALL BE APPLIED FOR & PERMITTED UNDER A SEPARATE SIGNAGE SUBMITTAL.
- G.C. SHALL PROVIDE BLOCKING IN STUD WALL BEHIND EACH SIGN AS REQUIRED BY SIGN VENDOR - FIELD VERIFY REQUIREMENTS W/ VENDOR & OWNER'S REPRESENTATIVE.
- ALL FLASHING, RIDGE CAPS, DRIP EDGE ETC. SHALL MATCH GUTTER & DOWNSPOUT MANUFACTURER'S STANDARD DETAILS. PROVIDE VENTED RIDGE CAP WHERE SHOWN.
- EXHAUST FAN, VTRS & SIMILAR ITEMS ON ROOF SHALL BE PAINTED - SEE EXTERIOR FINISHES.
- ALL MASONRY WITH CORNER EXPOSURES TO HAVE SAME PROFILE AS FACE OF THE STANDARD MASONRY PRODUCT. NO CUT SURFACE ARE TO BE EXPOSED
- ALL EXTERIOR SECURITY CAMERAS SHALL BE INSTALLED OVER ELECTRICAL BOXES RECESSED FLUSH WITH THE EXTERIOR WALL FINISH - REFER TO ELECTRICAL FOR ADDITIONAL INFORMATION.

**EXTERIOR FINISHES**

EXTERIOR INSULATED FINISH SYSTEM:	DRYVIT (SANDPEBBLE FINE) COLOR: E.I.F.S. 1 = #113 AMARILLO WHITE
FACE BRICK WAINSCOT: (GRADE TO 4'-0" ABOVE GRADE)	BELDEN - "MODULAR MIDLAND BLEND" ALL OUTSIDE CORNERS OF SOLDIER COURSE SHALL UTILIZE SOLID BRICK - NO MITERS
MORTAR:	LEHIGH STANDARD KIT - "BEIGE"
MASONRY SEALER:	ALL MASONRY SURFACES SHALL BE TREATED W/SEALER REFER TO SPECIFICATIONS.
STANDING SEAM AWNING:	FIRESTONE UNA-CLAD KYNAR 500 / HYLAR METAL 5000 FLUOROCARBON STEEL "CHAMPAGNE METALLIC" UNDERSIDE & FRAME TO BE PAINTED SW6152 "SUPERIOR BRONZE"
ROOF SHINGLES:	OWENS CORNING DURATION SERIES "DRIFTWOOD"
MISC. ROOF VENTS, FANS, ETC.:	PAINT SW7046 "ANONYMOUS"
GUTTER, DOWNSPOUTS, FASCIA, EXTERIOR SOFFIT, & EXPOSED TRIM:	DIMENSIONAL METALS, INC. - "BEIGE"
STOREFRONT SYSTEM:	2x4 1/2" KAWNEER TRIFAB V6 451T SERIES CLEAR ANODIZED ALUMINUM STOREFRONT SYSTEM W/1" INSULATED GLAZING.
H.M. DOORS & FRAMES:	FIELD PAINT W/ SHERWIN-WILLIAMS B66-1300 PRO-CYRL PRIMER FOLLOWED BY (2) FINISH COATS OF B66-300 SHER-CYRL HPA. COLOR SHALL BE SW-7515 "HOMESTEAD BROWN". PROVIDE MOCK-UP AND VERIFY COLOR W/ OWNER
O.H. DOOR FINISH:	CLEAR ANODIZED ALUMINUM
ACCESS PANEL:	STAINLESS STEEL

**SIGNAGE SCHEDULE**

NUMBER	DESCRIPTION	SIZE	ILLUMINATED	QUANTITY
600	LOGO SIGN	7'-8" x 5'-11" (45 SF)	INTERNALLY	2
PROVIDED BY OWNER, INSTALLED BY SIGN CONTRACTOR				
601	LANE INDICATOR SIGN	10'-0" x 1'-0" (10 SF)	NO	2
PROVIDED BY OWNER, INSTALLED BY SIGN CONTRACTOR				
602	OPEN SIGN	2'-7 1/2" x 11 1/2" (2.52 SF)	INTERNALLY	2
PROVIDED BY OWNER, INSTALLED BY SIGN CONTRACTOR				
603	MONUMENT SIGN	REFER TO SHEET A-11.1	INTERNALLY	1
PER LOCAL AND DEVELOPMENTAL RESTRICTIONS				
604	LOGO SIGN	4'-11" x 6'-5" (31 SF)	INTERNALLY	1
PROVIDED BY OWNER, INSTALLED BY SIGN CONTRACTOR				

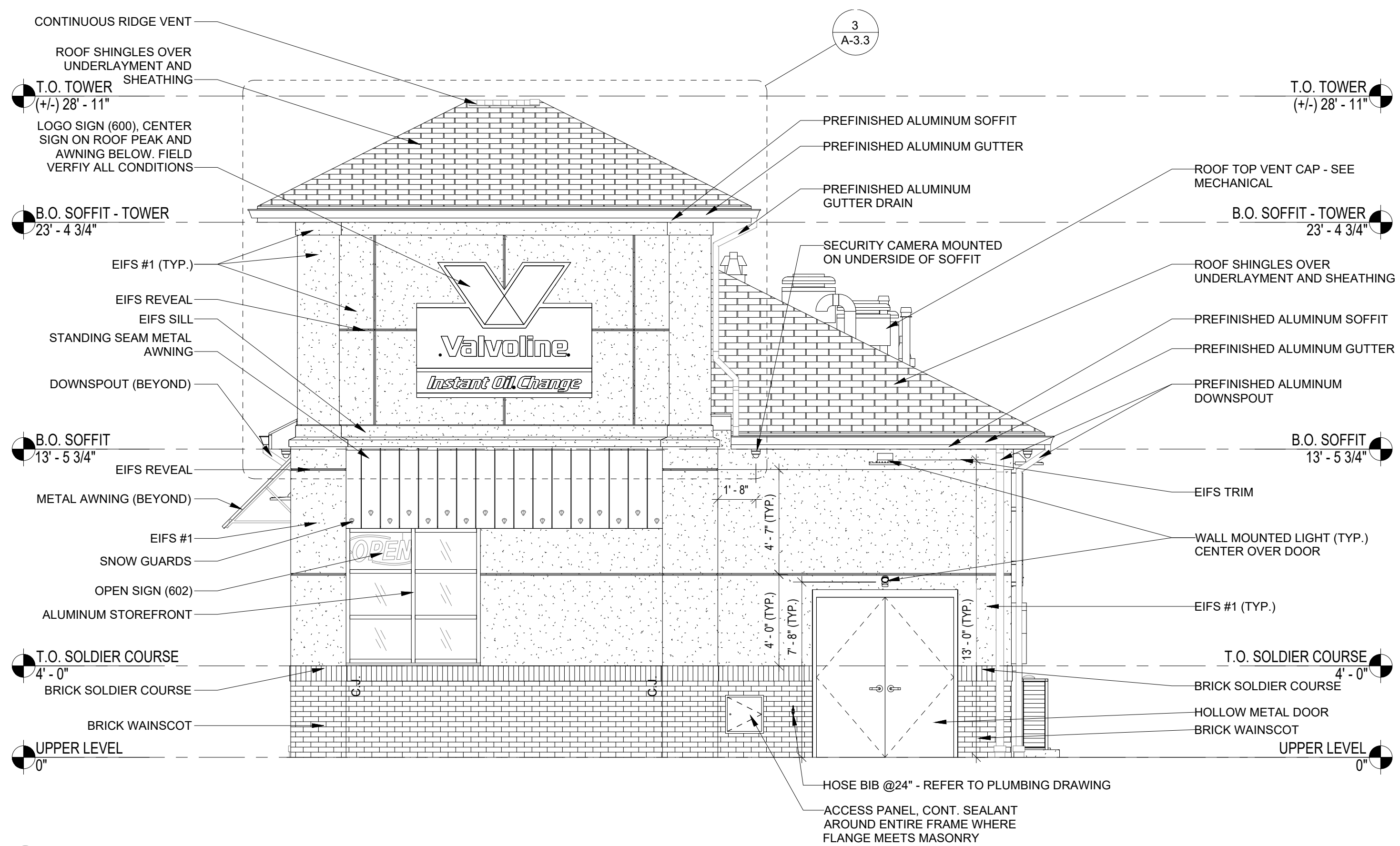

**2 EXTERIOR ELEVATION (OVERALL RIGHT)**  
 A-3.1 Scale: 1/4" = 1'-0"

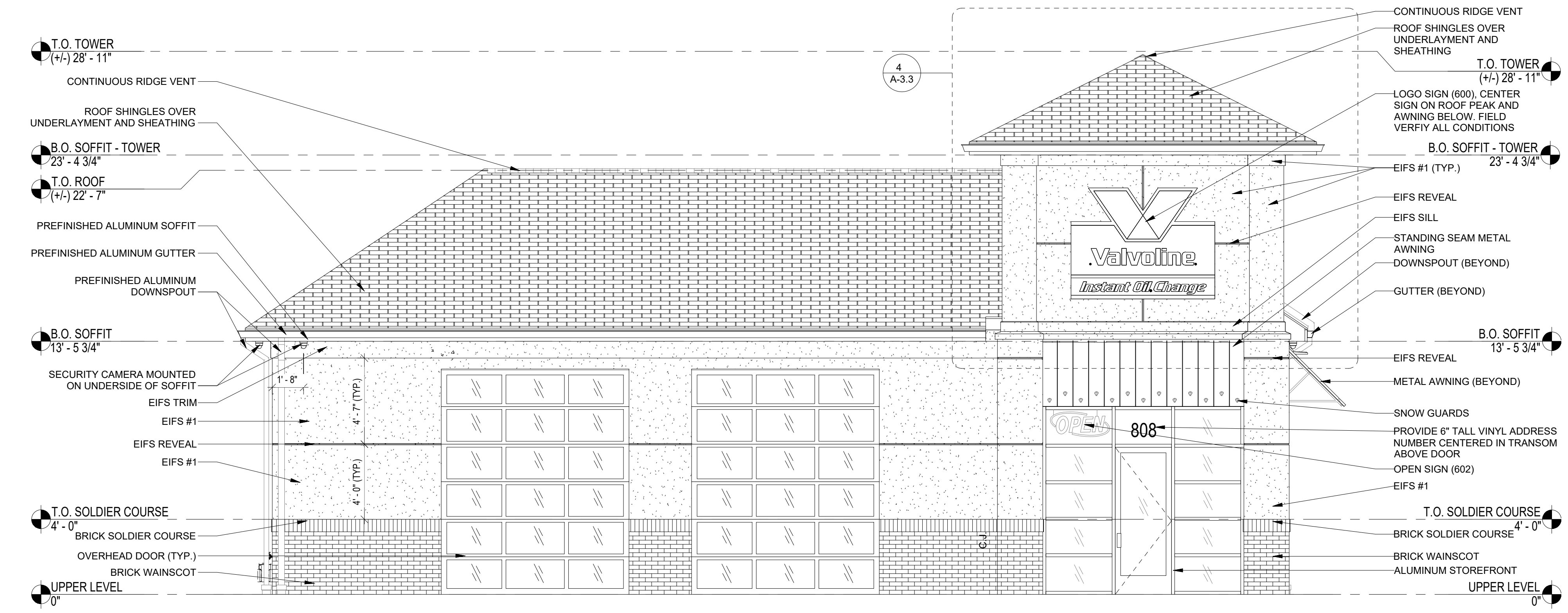

**1 EXTERIOR ELEVATION (OVERALL FRONT)**  
 A-3.1 Scale: 1/4" = 1'-0"

RYAN R. TRIPPAHN DESIGN, PLLC  
 CONTACT: RYAN R. TRIPPAHN  
 2635 PRATTMAN AVENUE SUITE 200  
 HOFFMAN ESTATES, IL 60192  
 PH: 847.452.7278  
 EMAIL: RTRIPPAHN@GMAIL.COM

**COPYRIGHT NOTICE**  
 This drawing is the property of the above referenced Professional and is not to be used for any purpose other than the specific project and site names herein, and cannot be reproduced in any manner without the express written permission from the Professional.

DATE	ISSUE
07/31/2024	OWNER REVIEW SET
02/14/2024	SITE PLAN REVIEW

PROFESSIONAL SEAL

PROFESSIONAL LICENSE NO.  
 ARC1917747  
 CERTIFICATE OF AUTHORIZATION NO.  
 FRM 21314408

PROFESSIONAL IN CHARGE  
 RYAN R. TRIPPAHN  
 PROJECT MANAGER  
 AG  
 QUALITY CONTROL  
 JL  
 DRAWN BY  
 JL, JG

PROJECT NAME



**VALVOLINE INSTANT OIL CHANGE**  
 808 COSHOCTON AVE.  
 MT. VERNON, OH 43050

PROJECT NUMBER  
 123000135

SHEET NAME  
**EXTERIOR ELEVATIONS**

SHEET #

**A-3.2**

**ELEVATION NOTES**

- EIFS SHALL BE DRYVIT, CLASS PB DRAINAGE SYSTEM WITH FLUID APPLIED WATER RESISTIVE BARRIER BEHIND INSULATION BOARD.
- SIGNAGE SHOWN ON THESE ELEVATIONS IS FOR GENERAL REFERENCE PURPOSES ONLY. ALL SIGNAGE SHALL BE APPLIED FOR & PERMITTED UNDER A SEPARATE SIGNAGE SUBMITTAL.
- G.C. SHALL PROVIDE BLOCKING IN STUD WALL BEHIND EACH SIGN AS REQUIRED BY SIGN VENDOR - FIELD VERIFY REQUIREMENTS W/ VENDOR & OWNER'S REPRESENTATIVE.
- ALL FLASHING, RIDGE CAPS, DRIP EDGE ETC. SHALL MATCH GUTTER & DOWNSPOUT MANUFACTURER'S STANDARD DETAILS. PROVIDE VENTED RIDGE CAP WHERE SHOWN.
- EXHAUST FAN, VTRS & SIMILAR ITEMS ON ROOF SHALL BE PAINTED - SEE EXTERIOR FINISHES.
- ALL MASONRY WITH CORNER EXPOSURES TO HAVE SAME PROFILE AS FACE OF THE STANDARD MASONRY PRODUCT. NO CUT SURFACE ARE TO BE EXPOSED
- ALL EXTERIOR SECURITY CAMERAS SHALL BE INSTALLED OVER ELECTRICAL BOXES RECESSED FLUSH WITH THE EXTERIOR WALL FINISH - REFER TO ELECTRICAL FOR ADDITIONAL INFORMATION.

**EXTERIOR FINISHES**

EXTERIOR INSULATED FINISH SYSTEM:	DRYVIT (SANDPEBBLE FINE) COLOR: E.I.F.S. 1 = #113 AMARILLO WHITE
FACE BRICK WAINSCOT: (GRADE TO 4'-0" ABOVE GRADE)	BELDEN - "MODULAR MIDLAND BLEND" ALL OUTSIDE CORNERS OF SOLDIER COURSE SHALL UTILIZE SOLID BRICK - NO MITERS
MORTAR:	LEHIGH STANDARD KIT - "BEIGE"
MASONRY SEALER:	ALL MASONRY SURFACES SHALL BE TREATED W/SEALER REFER TO SPECIFICATIONS.
STANDING SEAM AWNING:	FIRESTONE UNA-CLAD KYNAR 500 / HYLAR METAL 5000
ROOF SHINGLES:	OWENS CORNING DURATION SERIES "DRIFTWOOD"
MISC. ROOF VENTS, FANS, ETC.:	PAINT SW7046 "ANONYMOUS"
GUTTER, DOWNSPOUTS, FASCIA, EXTERIOR SOFFIT, & EXPOSED TRIM:	DIMENSIONAL METALS, INC. - "BEIGE"
STOREFRONT SYSTEM:	2x4 1/2" KAWNEER TRIFAB VG 451T SERIES CLEAR ANODIZED ALUMINUM STOREFRONT SYSTEM W/1" INSULATED GLAZING.
H.M. DOORS & FRAMES:	FIELD PAINT W/ SHERWIN-WILLIAMS B66-1300 PRO-CYRL PRIMER FOLLOWED BY (2) FINISH COATS OF B66-300 SHER-CYRL HPA. COLOR SHALL BE SW-7515 "HOMESTEAD BROWN". PROVIDE MOCK-UP AND VERIFY COLOR W/ OWNER
O.H. DOOR FINISH:	CLEAR ANODIZED ALUMINUM
ACCESS PANEL:	STAINLESS STEEL

**SIGNAGE SCHEDULE**

NUMBER	DESCRIPTION	SIZE	ILLUMINATED	QUANTITY
600	LOGO SIGN	7'-8" x 5'-11" (45 SF)	INTERNALLY	2
PROVIDED BY OWNER, INSTALLED BY SIGN CONTRACTOR				
601	LANE INDICATOR SIGN	10'-0" x 1'-0" (10 SF)	NO	2
PROVIDED BY OWNER, INSTALLED BY SIGN CONTRACTOR				
602	OPEN SIGN	2'-7 1/2" x 11 1/2" (2.52 SF)	INTERNALLY	2
PROVIDED BY OWNER, INSTALLED BY SIGN CONTRACTOR				
603	MONUMENT SIGN	REFER TO SHEET A-11.1	INTERNALLY	1
PER LOCAL AND DEVELOPMENTAL RESTRICTIONS				
604	LOGO SIGN	4'-11" x 6'-5" (31 SF)	INTERNALLY	1
PROVIDED BY OWNER, INSTALLED BY SIGN CONTRACTOR				

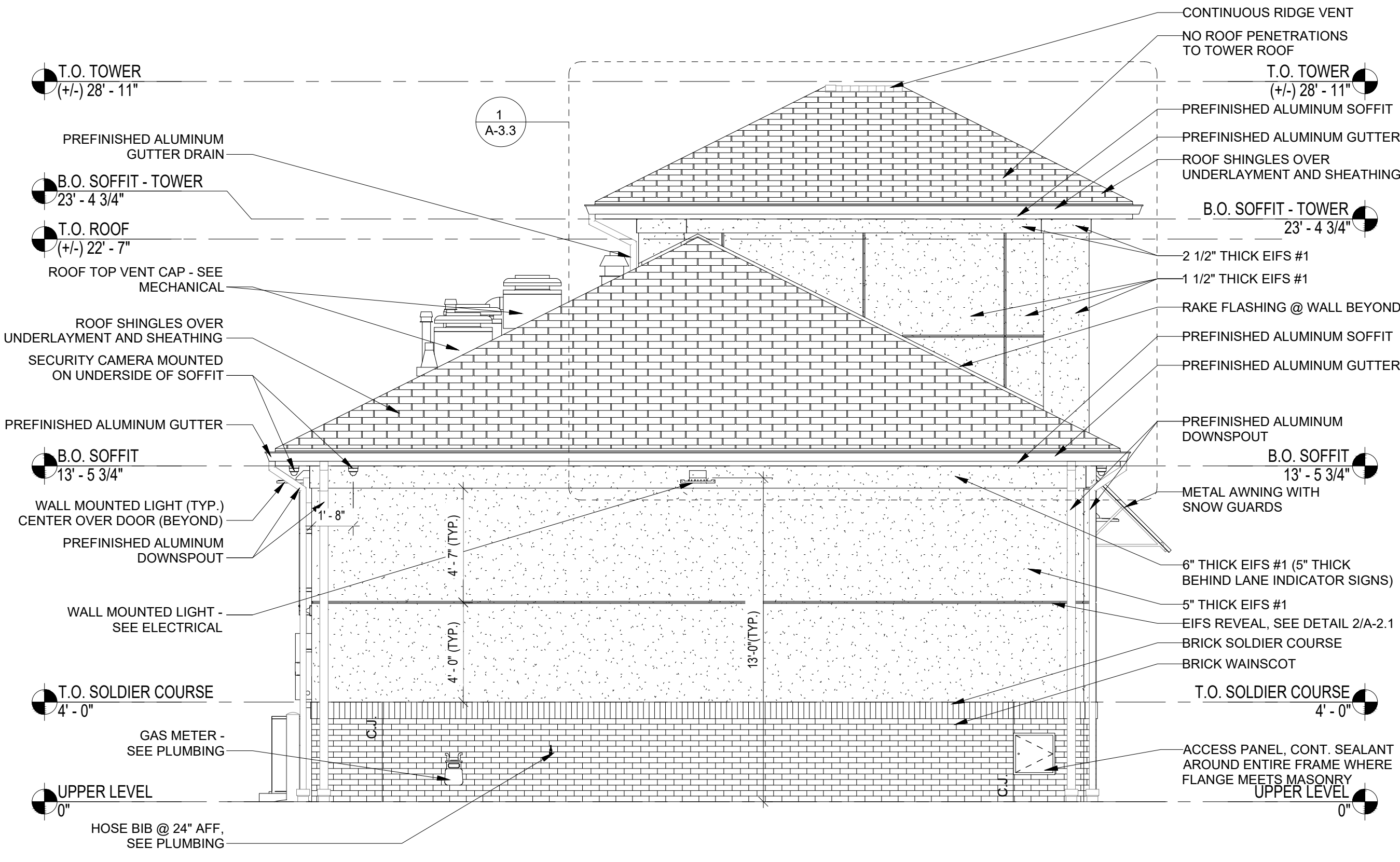

**2 EXTERIOR ELEVATION (OVERALL LEFT)**

A-3.2 Scale: 1/4" = 1'-0"

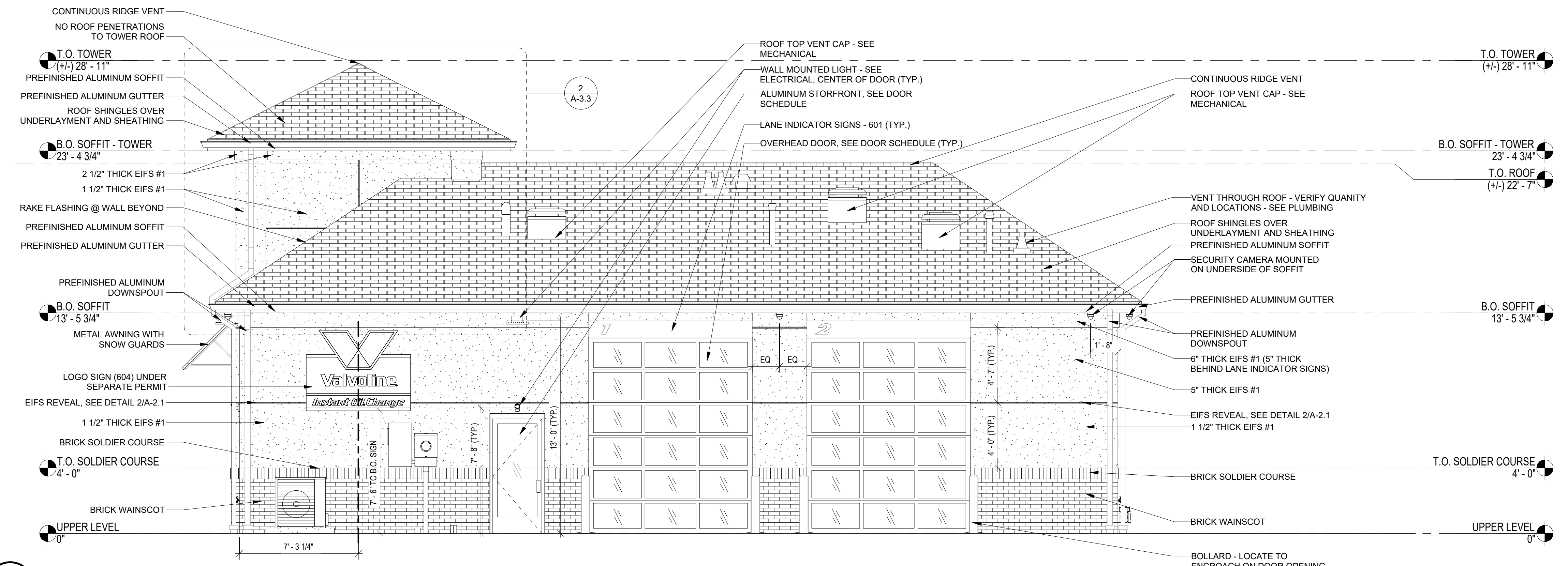

**1 EXTERIOR ELEVATION (OVERALL REAR)**

A-3.2 Scale: 1/4" = 1'-0"

Attachment: site\_plan\_review\_20240213 (3975 : 2024-02-06)



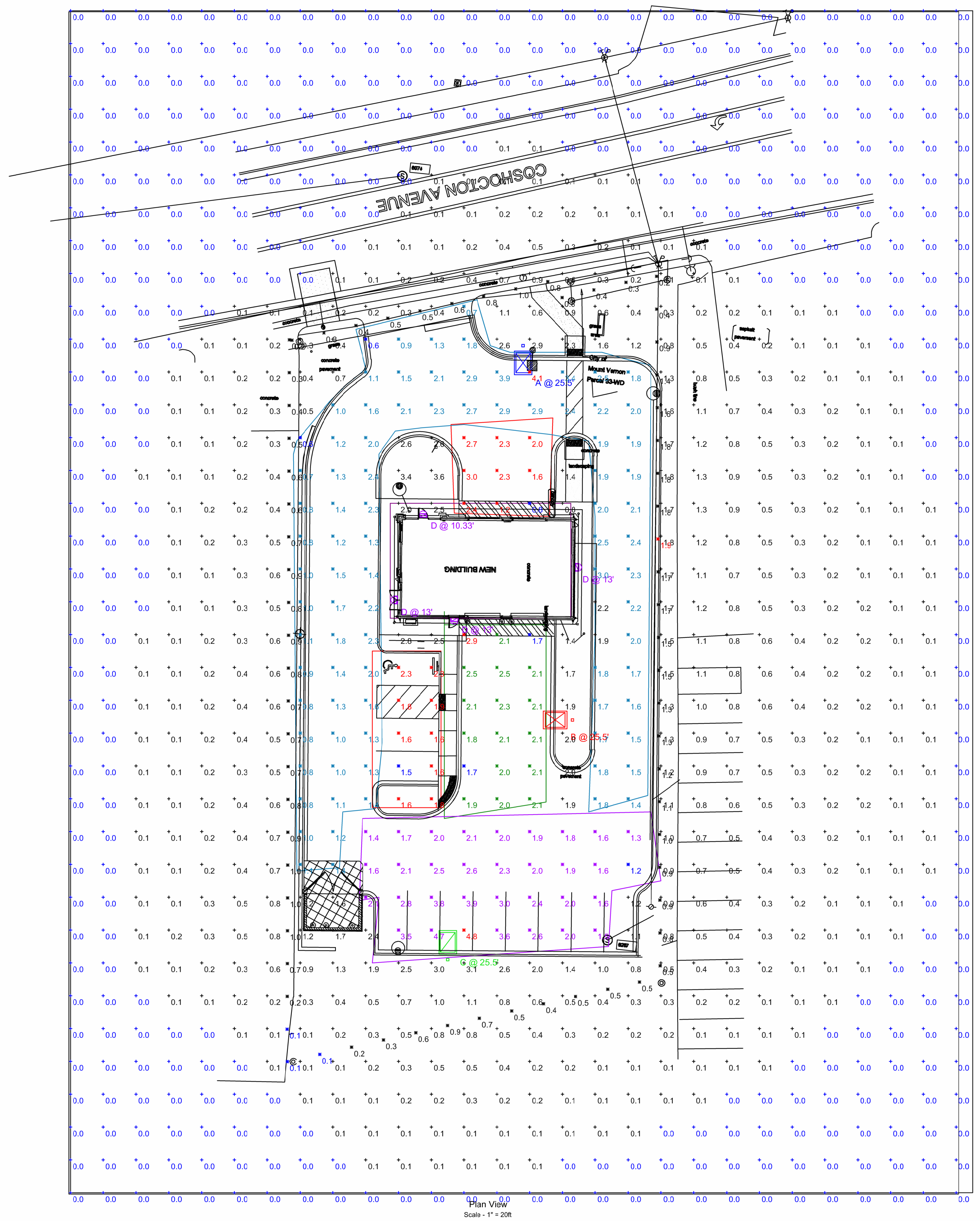

**Note**  
 Acuity Brands Lighting Inc. This document contains confidential and proprietary information of Acuity Brands Lighting. This document may only be used by or for the benefit of Acuity Brands Lighting's representatives and Customers. This application design is not a professional engineering drawing and the design, including reported data and calculated results, is provided for informational purposes only without any warranty as to accuracy, completeness, safety or otherwise. The design is the result of calculations made using Visual lighting application software, photometric/radiometric data measured in a laboratory, and certain computational and modeling assumptions. Far-field photometric/radiometric data may have been used to perform one or more calculations. Photometric/radiometric data is typically collected under far-field measurement conditions; far-field data is generally not representative of near-field geometric conditions. When using the far-field photometric/radiometric data, the Visual software applies certain generalizing assumptions to approximate near-field performance. These assumptions may result in significant inaccuracies in individual calculated luminous and/or radiant power quantities in areas where a source is in close proximity to a particular surface or point. The modeling of radiant flux exchange used in the Visual software requires a uniform exitance across each reflecting surface. The Visual software approximates the uniform surface exitance condition by adaptively subdividing surfaces with non-uniform exitance into subsurfaces with sufficiently uniform exitance gradient. Practical restrictions, due to computer hardware limitations, may prevent the subdivision procedure from subdividing surfaces with high exitance gradients into subsurfaces with sufficiently uniform exitance gradients, introducing potential discretization error into the calculated values. Calculations performed by Visual software assume that all reflected flux is reflected in a perfectly diffuse (Lambertian) and spectrally uniform manner across the spectral range being analyzed. If actual reflectance characteristics differ from these assumptions, observed luminous and/or radiant power quantities may differ from the predicted quantities. As a result of the computational limitations and simplifying modeling assumptions described above, and/or variations in actual product performance from tested product samples, the accuracy of calculated out values identifying expected radiometric quantities and any resulting derived radiation dose calculation may be adversely affected. In addition, the accuracy of the application design may be adversely affected if information about the physical space provided to Acuity Brands Lighting is incomplete, inaccurate, outdated or not in the required format (including but not limited to floor plans, space layout, reflected ceiling plans, physical structures, electrical design or specifications) if incorrect assumptions are made because such are not appropriate for the space. Furthermore, actual actual field performance may differ from performance calculated using laboratory measurement as a result of miscalculations related to deficiencies in the information provided about the physical space, degradation factors in the end-user environment (including, but not limited to, voltage variation and dirt accumulation), or other possible variations in field conditions. Finally, lamp lumen depreciation and/or depreciation in lamp radiant intensity may result in performance over time that differs performance calculated using a new lamp. Light loss factors may have been used in the application design to estimate such depreciation, but flaws in these estimates may also result in performance over time that differ from the calculated performance. It is the obligation of the end-user to consult with appropriately qualified Professional Engineer (s) to determine whether this application design meets the applicable requirements for performance, code compliance, safety, suitability and effectiveness for use in a particular application. In no event will Acuity Brands Lighting be responsible for any loss resulting from any use of this design.

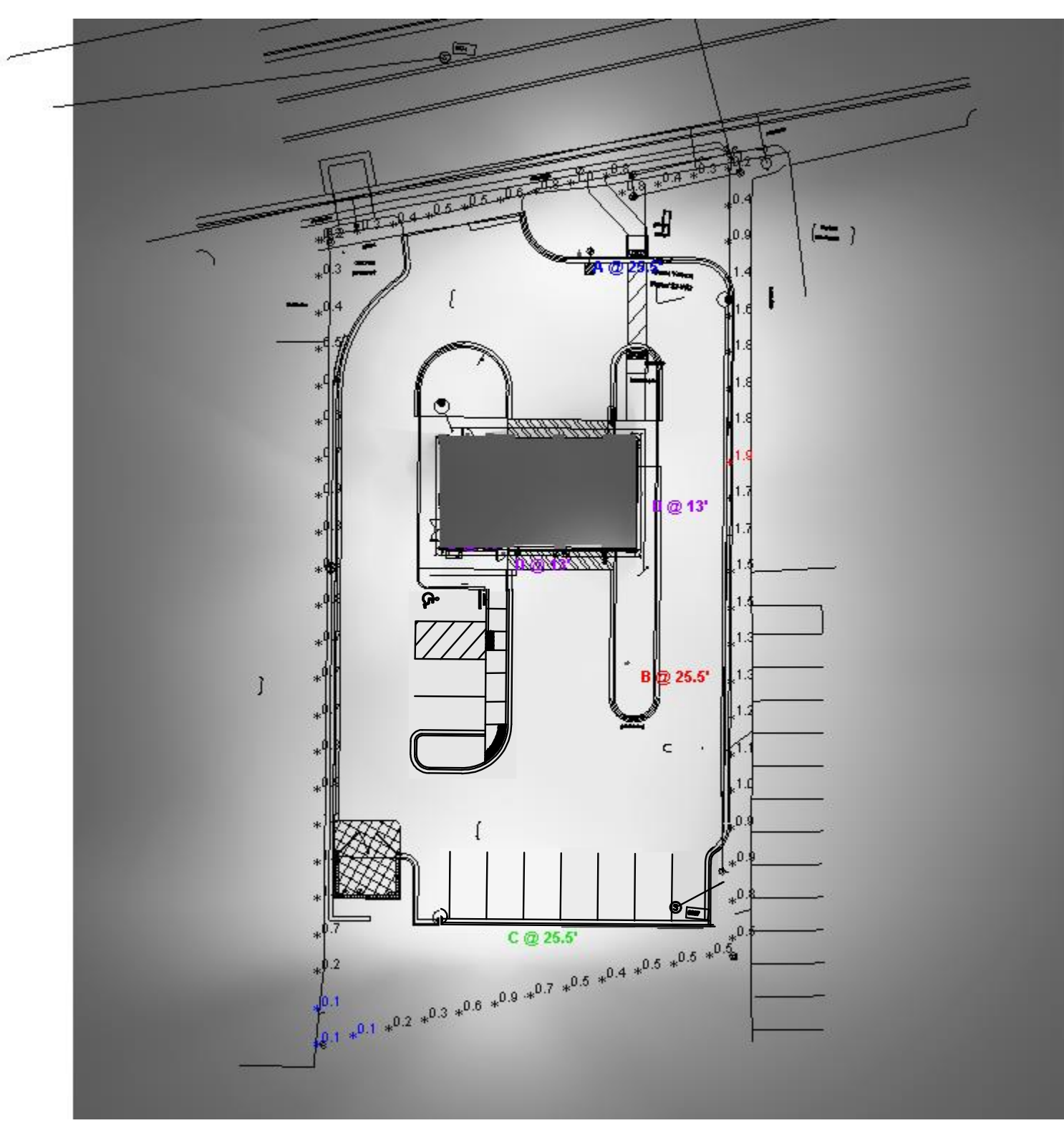

**D-Series Size 1 LED Wall Luminaire**

**Specifications Luminaire**  
 Width: 13.34" (340mm) | Weight: 12 lbs (5.4kg)  
 Depth: 5" (127mm) | ELCW Weight: 10 lbs (4.5kg)  
 Height: 6.38" (162mm) | ELCW Height: 6.38" (162mm)

**Back Box (BW, ELCW)**  
 Width: 13.34" (340mm) | Weight: 5 lbs (2.3kg)  
 Depth: 4" (102mm) | ELCW Weight: 10 lbs (4.5kg)  
 Height: 6.38" (162mm) | ELCW Height: 6.38" (162mm)

**Introduction**  
 The D-Series Wall Luminaire is a stylish, fully integrated LED solution for building-mount applications. It features a sleek, modern design and is a carefully engineered to provide long-lasting, energy-efficient lighting with a variety of optical and control options for customized performance. With an expected service life of over 20 years of nighttime use and up to 74% in energy savings over comparable 250W metal halide luminaires, the D-Series Wall is a reliable, low-maintenance lighting solution that produces sites that are exceptionally illuminated.

**Ordering Information**  
 EXAMPLE: DSW1 LED 20C 1000 40K TSM MVOLT DDBTD

Code	Units	Substrate	Color Temperature	Beam Spread	Mounting	Notes
DSW1 LED	10	20C	1000K	120°	Spot Mount	DSW1 LED
DSW1 LED	10	20C	1000K	120°	Spot Mount	DSW1 LED
DSW1 LED	10	20C	1000K	120°	Spot Mount	DSW1 LED

**Accessories**  
 DSX1 LED: 1000K CCT Type R3 Distribution  
 DSX1 LED: 4000K CCT Type R5 Distribution  
 DSX1 LED: 4000K CCT Type R4 Distribution  
 DSW1 LED WITH (1) 10 LED LIGHT ENGINES, TYPE TFM OPTIC, 4000K, @ 1000mA

**RSX1 LED Area Luminaire**

**Specifications**  
 EPA: 0.57 ft (0.65 m)  
 SP: 21.8" (55.4 cm) | 1000 lumens  
 Length: 13.3" (33.8 cm)  
 Height: 11.7" (2.9 m) Main Body | 7.2" (18.4 cm) Arm | 23.0 lbs (11.1 kg)

**Introduction**  
 The new RSX LED Area family delivers maximum value by providing significant energy savings, long life and outstanding photometric performance at an affordable price. The RSX1 delivers 7000 to 17000 lumens allowing it to replace 70W to 400W HID luminaires. The RSX1 features an integral universal mounting mechanism that allows the luminaire to be mounted on most existing drill hole patterns. This "no-drill" solution provides significant labor savings. An easy access door on the bottom of mounting arm allows for wiring without opening the electrical compartment. A mast arm adaptor and an adjustable integral slip-filter are also available.

**Ordering Information**  
 EXAMPLE: RSX1 LED P4 40K R3 MVOLT SPA DDBTD

Code	Units	Substrate	Color Temperature	Beam Spread	Mounting	Notes
RSX1 LED	10	20C	1000K	120°	Spot Mount	RSX1 LED
RSX1 LED	10	20C	1000K	120°	Spot Mount	RSX1 LED
RSX1 LED	10	20C	1000K	120°	Spot Mount	RSX1 LED

**Accessories**  
 DSX1 LED: 1000K CCT Type R3 Distribution  
 DSX1 LED: 4000K CCT Type R5 Distribution  
 DSX1 LED: 4000K CCT Type R4 Distribution  
 DSW1 LED WITH (1) 10 LED LIGHT ENGINES, TYPE TFM OPTIC, 4000K, @ 1000mA

**Note**  
 1. Readings shown are based on a total LLF of as shown at grade. Data references the extrapolated performance projections in a 25c ambient based on 10,000 hrs of LED testing (per IESNA LM-90-08 and projected per IESNA TM-21-11).  
 2. Please refer to the light fixture symbol for mounting heights.  
 3. Product information can be obtained at www.AcuityBrands.com

**Statistics**

Description	Symbol	Avg	Max	Min	Max/Min	Avg/Min
PROPERTY LINE	X	0.8 fc	1.9 fc	0.1 fc	19.0:1	8.0:1
SITE CALCULATIONS	+	0.5 fc	4.8 fc	0.0 fc	N/A	N/A
DRIVEWAY	X	1.7 fc	4.1 fc	0.6 fc	6.8:1	2.8:1
FRONT BAY	X	2.0 fc	3.0 fc	0.8 fc	3.8:1	2.5:1
PARKING AREA	X	2.4 fc	4.8 fc	1.2 fc	4.0:1	2.0:1
PARKING LOT	X	1.8 fc	2.3 fc	1.5 fc	1.5:1	1.2:1
REAR BAY	X	2.1 fc	2.9 fc	1.7 fc	1.7:1	1.2:1

**Schedule**

Symbol	Label	QTY	Catalog Number	Description	Number Lamps	Lumens per Lamp	LLF	Wattage
X	A	1	RSX1 LED P4 40K R3	RSX Area Fixture Size 1 P4 Lumen Package 4000K CCT Type R3 Distribution	1	16359	0.9	133.14
X	B	1	RSX1 LED P4 40K R5	RSX Area Fixture Size 1 P4 Lumen Package 4000K CCT Type R5 Distribution	1	16795	0.9	133.14
X	C	1	RSX1 LED P4 40K R4	RSX Area Fixture Size 1 P4 Lumen Package 4000K CCT Type R4 Distribution	1	16573	0.9	133.14
X	D	4	DSW1 LED 10C 1000 40K TFM MVOLT	DSW1 LED WITH (1) 10 LED LIGHT ENGINES, TYPE TFM OPTIC, 4000K, @ 1000mA	1	3945	0.9	38.8

Designer  
 R.A. MCILRATH  
 Date  
 1/31/2024  
 Scale  
 As Shown  
 Drawing No.  
 250833-1 A1  
 Summary



PLANTING SPECIFICATIONS

GENERAL

- A. QUALIFICATIONS OF LANDSCAPE CONTRACTOR
1. ALL LANDSCAPE WORK SHOWN ON THESE PLANS SHALL BE PERFORMED BY A SINGLE FIRM SPECIALIZING IN LANDSCAPE PLANTING.
2. A LIST OF SUCCESSFULLY COMPLETED PROJECTS OF THIS TYPE, SIZE AND NATURE MAY BE REQUESTED BY THE OWNER FOR FURTHER QUALIFICATION MEASURES.
3. THE LANDSCAPE CONTRACTOR SHALL HOLD A VALID CONTRACTOR'S LICENSE ISSUED BY THE APPROPRIATE LOCAL JURISDICTION.
B. SCOPE OF WORK
1. WORK COVERED BY THESE SECTIONS INCLUDES THE FURNISHING AND PAYMENT OF ALL MATERIALS, LABOR, SERVICES, EQUIPMENT, LICENSES, TAXES AND ANY OTHER ITEMS THAT ARE NECESSARY FOR THE EXECUTION, INSTALLATION AND COMPLETION OF ALL WORK, SPECIFIED HEREIN AND / OR SHOWN ON THE LANDSCAPE PLANS, NOTES, AND DETAILS.
2. ALL WORK SHALL BE PERFORMED IN ACCORDANCE WITH ALL APPLICABLE LAWS, CODES AND REGULATIONS REQUIRED BY AUTHORITIES HAVING JURISDICTION OVER SUCH WORK, INCLUDING ALL INSPECTIONS AND PERMITS REQUIRED BY FEDERAL, STATE AND LOCAL AUTHORITIES IN SUPPLY, TRANSPORTATION AND INSTALLATION OF MATERIALS.
3. THE LANDSCAPE CONTRACTOR SHALL VERIFY THE LOCATION OF ALL UNDERGROUND UTILITY LINES (WATER, SEWER, ELECTRICAL, TELEPHONE, GAS, CABLE, TELEVISION, ETC.) PRIOR TO THE START OF ANY WORK.

PRODUCTS

- A. ALL MANUFACTURED PRODUCTS SHALL BE NEW.
B. CONTAINER AND BALLED-AND-BURLAPPED PLANTS:
1. FURNISH NURSERY-GROWN PLANTS COMPLYING WITH ANSI Z60.1-2014. PROVIDE WELL-SHAPED, FULLY BRANCHED, HEALTHY, VIGOROUS STOCK FREE OF DISEASE, INSECTS, EGGS, LARVAE, AND DEFECTS SUCH AS KNOTS, SUN SCALD, INJURIES, ABRASIONS, AND DISFIGUREMENT. ALL PLANTS WITHIN A SPECIES SHALL HAVE SIMILAR SIZE, AND SHALL BE OF A FORM TYPICAL FOR THE SPECIES. ALL TREES SHALL BE OBTAINED FROM SOURCES WITHIN 200 MILES OF THE PROJECT SITE, AND WITH SIMILAR CLIMATIC CONDITIONS.
2. ROOT SYSTEMS SHALL BE HEALTHY, DENSELY BRANCHED ROOT SYSTEMS, NON-POT-BOUND, FREE FROM ENCIRCLING AND/OR GIRDLING ROOTS, AND FREE FROM ANY OTHER ROOT DEFECTS (SUCH AS J-SHAPED ROOTS).
3. TREES MAY BE PLANTED FROM CONTAINERS OR BALLED-AND-BURLAPPED (B&B), UNLESS SPECIFIED ON THE PLANTING LEGEND. BARE-ROOT TREES ARE NOT ACCEPTABLE.
4. ANY PLANT DEEMED UNACCEPTABLE BY THE LANDSCAPE ARCHITECT OR OWNER SHALL BE IMMEDIATELY REMOVED FROM THE SITE AND SHALL BE REPLACED WITH AN ACCEPTABLE PLANT OF LIKE TYPE AND SIZE AT THE CONTRACTOR'S OWN EXPENSE. ANY PLANTS APPEARING TO BE UNHEALTHY, EVEN IF DETERMINED TO STILL BE ALIVE, SHALL NOT BE ACCEPTED. THE LANDSCAPE ARCHITECT AND OWNER SHALL BE THE SOLE JUDGES AS TO THE ACCEPTABILITY OF PLANT MATERIAL.
5. ALL TREES SHALL BE STANDARD IN FORM, UNLESS OTHERWISE SPECIFIED. TREES WITH CENTRAL LEADERS WILL NOT BE ACCEPTED IF LEADER IS DAMAGED OR REMOVED. PRUNE ALL DAMAGED TWIGS AFTER PLANTING.
6. CALIPER MEASUREMENTS FOR STANDARD (SINGLE TRUNK) TREES SHALL BE AS FOLLOWS: SIX INCHES ABOVE THE ROOT FLARE FOR TREES UP TO AND INCLUDING FOUR INCHES IN CALIPER, AND TWELVE INCHES ABOVE THE ROOT FLARE FOR TREES EXCEEDING FOUR INCHES IN CALIPER.
7. MULTI-TRUNK TREES SHALL BE MEASURED BY THEIR OVERALL HEIGHT, MEASURED FROM THE TOP OF THE ROOT BALL. WHERE CALIPER MEASUREMENTS ARE USED, THE CALIPER SHALL BE CALCULATED AS ONE-HALF OF THE SUM OF THE CALIPER OF THE THREE LARGEST TRUNKS.
8. ANY TREE OR SHRUB SHOWN TO HAVE EXCESS SOIL PLACED ON TOP OF THE ROOT BALL, SO THAT THE ROOT FLARE HAS BEEN COMPLETELY COVERED, SHALL BE REJECTED.
C. SOD: PROVIDE WELL-ROOTED SOD OF THE VARIETY NOTED ON THE PLANS. SOD SHALL BE CUT FROM HEALTHY, MATURE TURF WITH SOIL THICKNESS OF 3/4" TO 1". EACH PALLETT OF SOD SHALL BE ACCOMPANIED BY A CERTIFICATE FROM SUPPLIER STATING THE COMPOSITION OF THE SOD.
D. SEED: PROVIDE CERTIFIED BLUEGRASS/FESCUE/PERENNIAL RYE SEED MIX, APPLIED AT THE RATE OF 7 LBS/1000 SF, PLS.
1. SEED SHALL BE FRESH, CLEAN, DRY, NEW-CROP SEED COMPLYING WITH AOSA'S "RULES FOR TESTING SEEDS" FOR PURITY AND GERMINATION TOLERANCES.
2. DELIVER SEED IN ORIGINAL, UNOPENED CONTAINERS SHOWING WEIGHT, CERTIFIED ANALYSIS, NAME, AND ADDRESS OF PRODUCER. STORE IN A DRY, ENCLOSED LOCATION.
E. TOPSOIL: SANDY TO CLAY LOAM TOPSOIL, FREE OF STONES LARGER THAN 1/2 INCH, FOREIGN MATTER, PLANTS, ROOTS, AND SEEDS.
F. COMPOST: WELL-COMPOSTED, STABLE, AND WEED-FREE ORGANIC MATTER, pH RANGE OF 5.5 TO 8; MOISTURE CONTENT 35 TO 55 PERCENT BY WEIGHT; 100 PERCENT PASSING THROUGH 3/4-INCH SIEVE; SOLUBLE SALT CONTENT OF 5 TO 10 DECISIEMENS/M; NOT EXCEEDING 0.5 PERCENT INERT CONTAMINANTS AND FREE OF SUBSTANCES TOXIC TO PLANTINGS. NO MANURE OR ANIMAL-BASED PRODUCTS SHALL BE USED.
G. FERTILIZER: GRANULAR FERTILIZER CONSISTING OF NITROGEN, PHOSPHORUS, POTASSIUM, AND OTHER NUTRIENTS IN PROPORTIONS, AMOUNTS, AND RELEASE RATES RECOMMENDED IN A SOIL REPORT FROM A QUALIFIED SOIL-TESTING AGENCY (SEE BELOW).
H. MULCH: SIZE AND TYPE AS INDICATED ON PLANS, FREE FROM DELETERIOUS MATERIALS AND SUITABLE AS A TOP DRESSING OF TREES AND SHRUBS.
I. TREE STAKING AND GUYING
1. STAKES: 8' LONG GREEN METAL T-POSTS.
2. GUY AND TIE WIRE: ASTM A 641, CLASS 1, GALVANIZED-STEEL WIRE, 2-STRAND, TWISTED, 0.106 INCH DIAMETER.
3. STRAP CHAFING GUARD: REINFORCED NYLON OR CANVAS AT LEAST 1-1/2 INCH WIDE, WITH GROMMETS TO PROTECT TREE TRUNKS FROM DAMAGE.
J. PRE-EMERGENT HERBICIDES: ANY GRANULAR, NON-STAINING PRE-EMERGENT HERBICIDE THAT IS LABELED FOR THE SPECIFIC ORNAMENTALS OR TURF ON WHICH IT WILL BE UTILIZED. PRE-EMERGENT HERBICIDES SHALL BE APPLIED PER THE MANUFACTURER'S LABELED RATES.
K. MAINTENANCE EDGE AGGREGATE: ANGULAR TO SUB-ANGULAR BASALT, 3/4-INCH DIAMETER, WASHED, OR APPROVED EQUAL.
L. FILTER FABRIC: SYNTHETIC, NON-WOVEN GEOTEXTILE FABRIC, WEIGHING 2 TO 4 OUNCES PER SQUARE YARD WITH A MINIMUM GRAB TENSILE STRENGTH OF 35 POUNDS AND PERMEABILITY OF 0.03 CM/SEC.

METHODS

- A. SOIL PREPARATION
1. BEFORE STARTING WORK, THE LANDSCAPE CONTRACTOR SHALL VERIFY THAT THE GRADE OF ALL LANDSCAPE AREAS ARE WITHIN +/-0.1' OF FINISH GRADE. THE CONTRACTOR SHALL NOTIFY THE OWNER IMMEDIATELY SHOULD ANY DISCREPANCIES EXIST.
2. SOIL TESTING:
a. AFTER FINISH GRADES HAVE BEEN ESTABLISHED, CONTRACTOR SHALL HAVE SOIL SAMPLES FROM THE PROJECT'S LANDSCAPE AREAS TESTED BY AN ESTABLISHED SOIL TESTING LABORATORY. EACH SAMPLE SUBMITTED TO THE LAB SHALL CONTAIN NO LESS THAN ONE QUART OF SOIL, TAKEN FROM BETWEEN THE SOIL SURFACE AND 6" DEPTH. IF NO SAMPLE LOCATIONS ARE INDICATED ON THE PLANS, THE CONTRACTOR SHALL TAKE A MINIMUM OF THREE SAMPLES FROM VARIOUS REPRESENTATIVE LOCATIONS FOR TESTING.
b. THE CONTRACTOR SHALL HAVE THE SOIL TESTING LABORATORY PROVIDE RESULTS FOR THE FOLLOWING: SOIL TEXTURAL CLASS, GENERAL SOIL FERTILITY, pH, ORGANIC MATTER CONTENT, SALT (CEC), LIME, SODIUM ADSORPTION RATIO (SAR) AND BORON CONTENT.
c. THE CONTRACTOR SHALL ALSO SUBMIT THE PROJECT'S PLANT LIST TO THE LABORATORY ALONG WITH THE SOIL SAMPLES.
d. THE SOIL REPORT PRODUCED BY THE LABORATORY SHALL CONTAIN RECOMMENDATIONS FOR THE FOLLOWING (AS APPROPRIATE): SOIL PREPARATION AND PLANTING RECOMMENDATIONS FOR GENERAL ORNAMENTAL PLANTS, XERIC PLANTS, TURF, AND NATIVE SEED, AS WELL AS PRE-PLANT FERTILIZER APPLICATIONS AND RECOMMENDATIONS FOR ANY OTHER SOIL RELATED ISSUES. THE REPORT SHALL ALSO PROVIDE A FERTILIZER PROGRAM FOR THE ESTABLISHMENT PERIOD AND FOR LONG-TERM MAINTENANCE.
3. THE CONTRACTOR SHALL INSTALL SOIL AMENDMENTS AND FERTILIZERS PER THE SOILS REPORT RECOMMENDATIONS. ANY CHANGE IN COST DUE TO THE SOIL REPORT RECOMMENDATIONS, EITHER INCREASE OR DECREASE, SHALL BE SUBMITTED TO THE OWNER WITH THE REPORT.
4. FOR BIDDING PURPOSES ONLY, THE SOIL PREPARATION SHALL CONSIST OF THE FOLLOWING:
a. TREES: INCORPORATE THE FOLLOWING AMENDMENTS INTO THE TOP 8" OF SOIL BY MEANS OF ROTOTILLING AFTER CROSS-RIPPING:
i. NITROGEN STABILIZED ORGANIC AMENDMENT - 4 CU. YDS. PER 1,000 S.F.
ii. 12-12-12 FERTILIZER (OR SIMILAR, ORGANIC, SLOW RELEASE) - 10 LBS. PER CU. YD.
iii. "CLAY BUSTER" OR EQUAL - USE MANUFACTURER'S RECOMMENDED RATE
iv. IRON SULPHATE - 2 LBS. PER CU. YD.
5. IN THE CONTEXT OF THESE PLANS, NOTES, AND SPECIFICATIONS, "FINISH GRADE" REFERS TO THE FINAL ELEVATION OF THE SOIL SURFACE (NOT TOP OF MULCH) AS INDICATED ON THE GRADING PLANS.
a. BEFORE STARTING WORK, THE LANDSCAPE CONTRACTOR SHALL VERIFY THAT THE ROUGH GRADES OF ALL LANDSCAPE AREAS ARE WITHIN +/-0.1' OF FINISH GRADE. SEE SPECIFICATIONS FOR MORE DETAILED INSTRUCTION ON TURF AREA AND PLANTING BED PREPARATION.
b. CONSTRUCT AND MAINTAIN FINISH GRADES AS SHOWN ON GRADING PLANS, AND CONSTRUCT AND MAINTAIN SLOPES AS RECOMMENDED BY THE GEOTECHNICAL REPORT. ALL LANDSCAPE AREAS SHALL HAVE POSITIVE DRAINAGE AWAY FROM STRUCTURES AT THE MINIMUM SLOPE SPECIFIED IN THE REPORT AND ON THE GRADING PLANS, AND AREAS OF POTENTIAL PONDING SHALL BE REGRADED TO BLEND IN WITH THE SURROUNDING GRADES AND ELIMINATE PONDING POTENTIAL.
c. THE LANDSCAPE CONTRACTOR SHALL DETERMINE WHETHER OR NOT THE EXPORT OF ANY SOIL WILL BE NEEDED, TAKING INTO ACCOUNT THE ROUGH GRADE PROVIDED, THE AMOUNT OF SOIL AMENDMENTS TO BE ADDED (BASED ON A SOIL TEST, PER SPECIFICATIONS), AND THE FINISH GRADES TO BE ESTABLISHED.
d. ENSURE THAT THE FINISH GRADE IN SHRUB AREAS IMMEDIATELY ADJACENT TO WALKS AND OTHER WALKING SURFACES, AFTER INSTALLING SOIL AMENDMENTS, IS 3" BELOW THE ADJACENT FINISH SURFACE, IN ORDER TO ALLOW FOR PROPER MULCH DEPTH. TAPER THE SOIL SURFACE TO MEET FINISH GRADE, AS SPECIFIED ON THE GRADING PLANS, AT APPROXIMATELY 18" AWAY FROM THE WALKS.
e. ENSURE THAT THE FINISH GRADE IN TURF AREAS IMMEDIATELY ADJACENT TO WALKS AND OTHER WALKING SURFACES, AFTER INSTALLING SOIL AMENDMENTS, IS 1" BELOW THE FINISH SURFACE OF THE WALKS. TAPER THE SOIL SURFACE TO MEET FINISH GRADE, AS SPECIFIED ON THE GRADING PLANS, AT APPROXIMATELY 18" AWAY FROM THE WALKS.
f. SHOULD ANY CONFLICTS AND/OR DISCREPANCIES ARISE BETWEEN THE GRADING PLANS, GEOTECHNICAL REPORT, THESE NOTES AND PLANS, AND ACTUAL CONDITIONS, THE CONTRACTOR SHALL IMMEDIATELY BRING SUCH ITEMS TO THE ATTENTION OF THE LANDSCAPE ARCHITECT, GENERAL CONTRACTOR, AND OWNER.
6. ONCE SOIL PREPARATION IS COMPLETE, THE LANDSCAPE CONTRACTOR SHALL ENSURE THAT THERE ARE NO DEBRIS, TRASH, OR STONES LARGER THAN 1" REMAINING IN THE TOP 6" OF SOIL.

SUBMITTALS

- 1. THE CONTRACTOR SHALL PROVIDE SUBMITTALS AND SAMPLES, IF REQUIRED, TO THE LANDSCAPE ARCHITECT, AND RECEIVE APPROVAL IN WRITING FOR SUCH SUBMITTALS BEFORE WORK COMMENCES.
2. SUBMITTALS SHALL INCLUDE PHOTOS OF PLANTS WITH A RULER OR MEASURING STICK FOR SCALE, PHOTOS OR SAMPLES OF ANY REQUIRED MULCHES, AND SOIL TEST RESULTS AND PREPARATION RECOMMENDATIONS FROM THE TESTING LAB (INCLUDING COMPOST AND FERTILIZER RATES AND TYPES, AND OTHER AMENDMENTS FOR TREE/SHRUB, TURF, AND SEED AREAS AS MAY BE APPROPRIATE).
3. SUBMITTALS SHALL ALSO INCLUDE MANUFACTURER CUT SHEETS FOR PLANTING ACCESSORIES SUCH AS TREE STAKES AND TIES, EDGING, AND LANDSCAPE FABRICS (IF ANY).
4. WHERE MULTIPLE ITEMS ARE SHOWN ON A PAGE, THE CONTRACTOR SHALL CLEARLY INDICATE THE ITEM BEING CONSIDERED.

GENERAL PLANTING

- 1. REMOVE ALL NURSERY TAGS AND STAKES FROM PLANTS.
2. EXCEPT IN AREAS TO BE PLANTED WITH ORNAMENTAL GRASSES, APPLY PRE-EMERGENT HERBICIDES AT THE MANUFACTURER'S RECOMMENDED RATE.
3. TRENCHING NEAR EXISTING TREES:
a. CONTRACTOR SHALL NOT DISTURB ROOTS 1-1/2" AND LARGER IN DIAMETER WITHIN THE CRITICAL ROOT ZONE (CRZ) OF EXISTING TREES, AND SHALL EXERCISE ALL POSSIBLE CARE AND PRECAUTIONS TO AVOID INJURY TO TREE ROOTS, TRUNKS, AND BRANCHES. THE CRZ IS DEFINED AS A CIRCULAR AREA EXTENDING OUTWARD FROM THE TREE TRUNK, WITH A RADIUS EQUAL TO 1' FOR EVERY 1" OF TRUNK DIAMETER-AT-BREAST-HEIGHT (4.5' ABOVE THE AVERAGE GRADE AT THE TRUNK).
b. ALL EXCAVATION WITHIN THE CRZ SHALL BE PERFORMED USING HAND TOOLS. NO MACHINE EXCAVATION OR TRENCHING OF ANY KIND SHALL BE ALLOWED WITHIN THE CRZ.
c. ALTER ALIGNMENT OF PIPE TO AVOID TREE ROOTS 1-1/2" AND LARGER IN DIAMETER. WHERE TREE ROOTS 1-1/2" AND LARGER IN DIAMETER ARE ENCOUNTERED IN THE FIELD, TUNNEL UNDER SUCH ROOTS. WRAP EXPOSED ROOTS WITH SEVERAL LAYERS OF BURLAP AND KEEP MOIST. CLOSE ALL TRENCHES WITHIN THE CANOPY DRIP LINES WITHIN 24 HOURS.
d. ALL SEVERED ROOTS SHALL BE HAND PRUNED WITH SHARP TOOLS AND ALLOWED TO AIR-DRY. DO NOT USE ANY SORT OF SEALERS OR WOUND PAINTS.

TREE PLANTING

- 1. TREE PLANTING HOLES SHALL BE EXCAVATED TO MINIMUM WIDTH OF TWO TIMES THE WIDTH OF THE ROOTBALL, AND TO A DEPTH EQUAL TO THE DEPTH OF THE ROOTBALL LESS TWO TO FOUR INCHES.
2. SCARIFY THE SIDES AND BOTTOM OF THE PLANTING HOLE PRIOR TO THE PLACEMENT OF THE TREE. REMOVE ANY GLAZING THAT MAY HAVE BEEN CAUSED DURING THE EXCAVATION OF THE HOLE.
3. FOR CONTAINER AND BOX TREES, TO REMOVE ANY POTENTIALLY GIRDLING ROOTS AND OTHER ROOT DEFECTS, THE CONTRACTOR SHALL SHAVE A 1" LAYER OFF OF THE SIDES AND BOTTOM OF THE ROOTBALL OF ALL TREES JUST BEFORE PLACING INTO THE PLANTING PIT. DO NOT "TEASE" ROOTS OUT FROM THE ROOTBALL.
4. INSTALL THE TREE ON UNDISTURBED SUBGRADE SO THAT THE TOP OF THE ROOTBALL IS TWO TO FOUR INCHES ABOVE THE SURROUNDING GRADE.
5. BACKFILL THE TREE HOLE UTILIZING THE EXISTING TOPSOIL FROM ON-SITE. ROCKS LARGER THAN 1" DIA. AND ALL OTHER DEBRIS SHALL BE REMOVED FROM THE SOIL PRIOR TO THE BACKFILL. SHOULD ADDITIONAL SOIL BE REQUIRED TO ACCOMPLISH THIS TASK, USE STORED TOPSOIL FROM ON-SITE OR IMPORT ADDITIONAL TOPSOIL FROM OFF-SITE AT NO ADDITIONAL COST TO THE OWNER. IMPORTED TOPSOIL SHALL BE OF SIMILAR TEXTURAL CLASS AND COMPOSITION IN THE ON-SITE SOIL.
6. TREES SHALL NOT BE PLANTED ON SLOPES (SUCH AS HEAVY WINDS OR SLOPES) REQUIRE STAKES TO KEEP TREES UPRIGHT. SHOULD STAKING BE REQUIRED, THE TOTAL NUMBER OF TREE STAKES (BEYOND THE MINIMUMS LISTED BELOW) WILL BE LEFT TO THE LANDSCAPE CONTRACTOR'S DISCRETION. SHOULD ANY TREES FALL OR LEAN, THE LANDSCAPE CONTRACTOR SHALL STRAIGHTEN THE TREE, OR REPLACE IT SHOULD IT BECOME DAMAGED. TREE STAKING SHALL ADHERE TO THE FOLLOWING GUIDELINES:
a. 1"-2" TREES TWO STAKES PER TREE
b. 2-1/2"-4" TREES THREE STAKES PER TREE
c. TREES OVER 4" CALIPER GUY AS NEEDED
d. MULTI-TRUNK TREES THREE STAKES PER TREE MINIMUM, QUANTITY AND POSITIONS AS NEEDED TO STABILIZE THE TREE
7. UPON COMPLETION OF PLANTING, CONSTRUCT AN EARTH WATERING BASIN AROUND THE TREE. COVER THE INTERIOR OF THE TREE RING WITH MULCH (TYPE AND DEPTH PER PLANS).

SODDING

- 1. SOD VARIETY TO BE AS SPECIFIED ON THE LANDSCAPE PLAN.
2. LAY SOD WITHIN 24 HOURS FROM THE TIME OF STRIPPING. DO NOT LAY IF THE GROUND IS FROZEN.
3. LAY THE SOD TO FORM A SOLID MASS WITH TIGHTLY FITTED JOINTS. BUTT ENDS AND SIDES OF SOD STRIPS - DO NOT OVERLAP. STAGGER STRIPS TO OFFSET JOINTS IN ADJACENT COURSES.
4. ROLL THE SOD TO ENSURE GOOD CONTACT OF THE SOD'S ROOT SYSTEM WITH THE SOIL UNDERNEATH.
5. WATER THE SOD THOROUGHLY WITH A FINE SPRAY IMMEDIATELY AFTER PLANTING TO OBTAIN AT LEAST SIX INCHES OF PENETRATION INTO THE SOIL BELOW THE SOD.

MULCH

- 1. INSTALL MULCH TOPDRESSING, TYPE AND DEPTH PER MULCH NOTE, IN ALL PLANTING AREAS AND TREE RINGS.
2. DO NOT INSTALL MULCH WITHIN 6" OF TREE ROOT FLARE AND WITHIN 24" OF HABITABLE STRUCTURES, EXCEPT AS MAY BE NOTED ON THESE PLANS. MULCH COVER WITHIN 6" OF CONCRETE WALKS AND CURBS SHALL NOT PROTRUDE ABOVE THE FINISH SURFACE OF THE WALKS AND CURBS. MULCH COVER WITHIN 12" OF WALLS SHALL BE AT LEAST 3" LOWER THAN THE TOP OF WALL.

CLEAN UP

- 1. DURING LANDSCAPE PREPARATION AND PLANTING, KEEP ALL PAVEMENT CLEAN AND ALL WORK AREAS IN A NEAT, ORDERLY CONDITION.
2. LEGALLY DISPOSE ALL EXCAVATED MATERIALS OFF THE PROJECT SITE.

INSPECTION AND ACCEPTANCE

- 1. UPON COMPLETION OF THE WORK, THE LANDSCAPE CONTRACTOR SHALL PROVIDE THE SITE CLEAN, FREE OF DEBRIS AND TRASH, AND SUITABLE FOR USE AS INTENDED. THE LANDSCAPE CONTRACTOR SHALL THEN REQUEST AN INSPECTION BY THE OWNER TO DETERMINE FINAL ACCEPTABILITY.
2. WHEN THE INSPECTED PLANTING WORK DOES NOT COMPLY WITH THE CONTRACT DOCUMENTS, THE LANDSCAPE CONTRACTOR SHALL REPLACE AND/OR REPAIR THE REJECTED WORK TO THE OWNER'S SATISFACTION WITHIN 24 HOURS.
3. THE LANDSCAPE MAINTENANCE PERIOD WILL NOT COMMENCE UNTIL THE LANDSCAPE WORK HAS BEEN RE-INSPECTED BY THE OWNER AND FOUND TO BE ACCEPTABLE. AT THAT TIME, A WRITTEN NOTICE OF FINAL ACCEPTANCE WILL BE ISSUED BY THE OWNER, AND THE MAINTENANCE AND GUARANTEE PERIODS WILL COMMENCE.

LANDSCAPE MAINTENANCE

- 1. THE LANDSCAPE CONTRACTOR SHALL BE RESPONSIBLE FOR THE MAINTENANCE OF ALL WORK SHOWN ON THESE PLANS FOR 90 DAYS BEYOND FINAL ACCEPTANCE OF ALL LANDSCAPE WORK BY THE OWNER. LANDSCAPE MAINTENANCE SHALL INCLUDE WEEKLY SITE VISITS FOR THE FOLLOWING ACTIONS (AS APPROPRIATE): PROPER PRUNING, RESTAKING OF TREES, RESETTling OF PLANTS THAT HAVE SETTLED, MOWING AND AERATION OF LAWNS, WEEDING, RESEEDING AREAS WHICH HAVE NOT GERMINATED WELL, TREATING FOR INSECTS AND DISEASES, REPLACEMENT OF MULCH, REMOVAL OF LITTER, REPAIRS TO THE IRRIGATION SYSTEM DUE TO FAULTY PARTS AND/OR WORKMANSHIP, AND THE APPROPRIATE WATERING OF ALL PLANTINGS. THE LANDSCAPE CONTRACTOR SHALL MAINTAIN THE IRRIGATION SYSTEM IN PROPER WORKING ORDER, WITH SCHEDULING ADJUSTMENTS BY SEASON TO MAXIMIZE WATER CONSERVATION. SHOULD SEEDING AND/OR SODDED AREAS NOT BE COVERED BY AN AUTOMATIC IRRIGATION SYSTEM, THE LANDSCAPE CONTRACTOR SHALL BE RESPONSIBLE FOR WATERING THESE AREAS AND OBTAINING A FULL, HEALTHY STAND OF PLANTS AT NO ADDITIONAL COST TO THE OWNER.
2. TO ACHIEVE FINAL ACCEPTANCE AT THE END OF THE MAINTENANCE PERIOD, ALL OF THE FOLLOWING CONDITIONS MUST OCCUR:
a. THE LANDSCAPE SHALL SHOW ACTIVE, HEALTHY GROWTH (WITH EXCEPTIONS MADE FOR SEASONAL DORMANCY). ALL PLANTS NOT MEETING THIS CONDITION SHALL BE REJECTED AND REPLACED BY HEALTHY PLANT MATERIAL PRIOR TO FINAL ACCEPTANCE.
b. ALL HARDSCAPE SHALL BE CLEANED PRIOR TO FINAL ACCEPTANCE.
c. SODDED AREAS MUST BE ACTIVELY GROWING AND MUST REACH A MINIMUM HEIGHT OF 1 1/2 INCHES BEFORE FIRST MOWING. HYDROMULCHED AREAS SHALL SHOW ACTIVE, HEALTHY GROWTH. BARE AREAS LARGER THAN TWELVE SQUARE INCHES MUST BE RESEEDDED OR RESEEDDED (AS APPROPRIATE) PRIOR TO FINAL ACCEPTANCE. ALL SODDED TURF SHALL BE NEATLY MOWED.

WARRANTY PERIOD, PLANT GUARANTEE AND REPLACEMENTS

- 1. THE LANDSCAPE CONTRACTOR SHALL GUARANTEE ALL TREES, SHRUBS, PERENNIALS, SOD, AND IRRIGATION SYSTEMS FOR A PERIOD OF ONE YEAR (90 DAYS FOR ANNUAL PLANTS). THE CONTRACTOR SHALL REPLACE, AT HIS OWN EXPENSE AND TO THE SATISFACTION OF THE OWNER, ANY PLANTS WHICH DIE IN THAT TIME, OR REPAIR ANY PORTIONS OF THE IRRIGATION SYSTEM WHICH OPERATE IMPROPERLY.
2. AFTER THE INITIAL MAINTENANCE PERIOD AND DURING THE GUARANTEE PERIOD, THE LANDSCAPE CONTRACTOR SHALL ONLY BE RESPONSIBLE FOR REPLACEMENT OF PLANTS WHEN PLANT DEATH CANNOT BE ATTRIBUTED DIRECTLY TO OVERWATERING OR OTHER DAMAGE BY HUMAN ACTIONS.
3. PROVIDE A MINIMUM OF (2) COPIES OF RECORD DRAWINGS TO THE OWNER UPON COMPLETION OF WORK. A RECORD DRAWING IS A RECORD OF ALL CHANGES THAT OCCURRED IN THE FIELD AND THAT ARE DOCUMENTED THROUGH CHANGE ORDERS, ADDENDA, OR CONTRACTOR/CONSULTANT DRAWING MARKUPS.

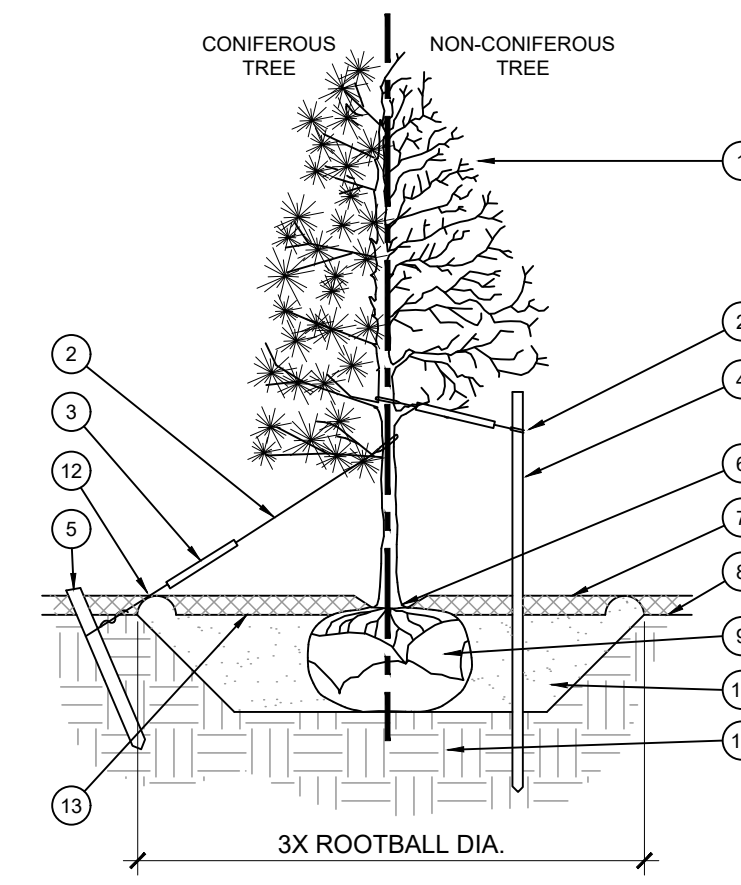

STAKING EXAMPLES (PLAN VIEW)

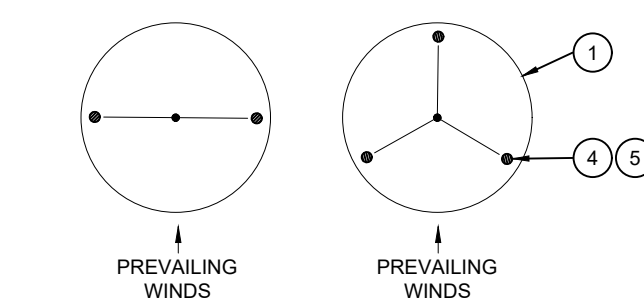

TREE PLANTING SCALE: NOT TO SCALE

- 1. TREE CANOPY.
2. CINC-H-TIES (24\"/>

- NOTES:
1. SCARIFY SIDES OF PLANTING PIT PRIOR TO SETTING TREE.
2. REMOVE EXCESS SOIL APPLIED ON TOP OF THE ROOTBALL THAT COVERS THE ROOT FLARE. THE PLANTING HOLE DEPTH SHALL BE SUCH THAT THE ROOTBALL RESTS ON UNDISTURBED SOIL, AND THE ROOT FLARE IS 2-4\"/>

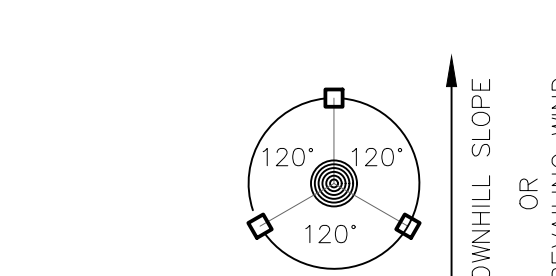

STAKING/GUYING LOCATION PLAN

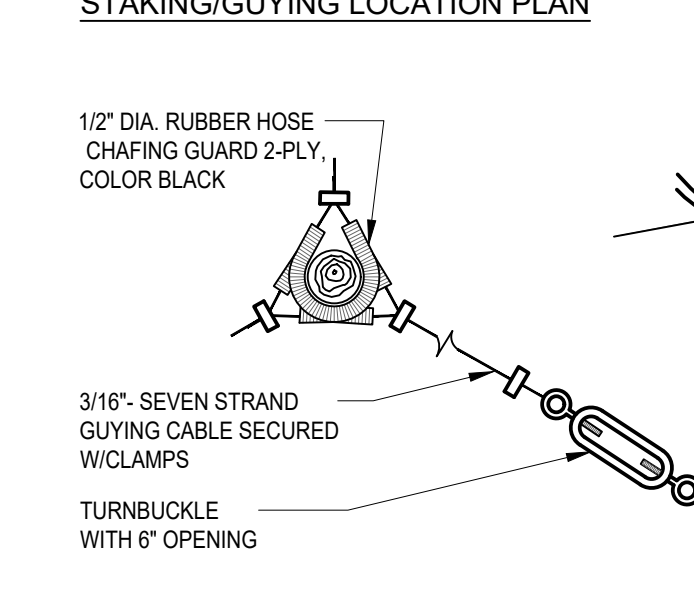

GUYING CABLE DETAIL PLAN

- NOTES:
ORIENT STAKING/GUYING TO PREVAILING WINDS AND SLOPES, EXCEPT ON SLOPES GREATER THAN 3:1 ORIENT TO SLOPE.
USE SAME STAKING/GUYING ORIENTATION FOR ALL PLANTS WITHIN EACH GROUPING OR AREA.

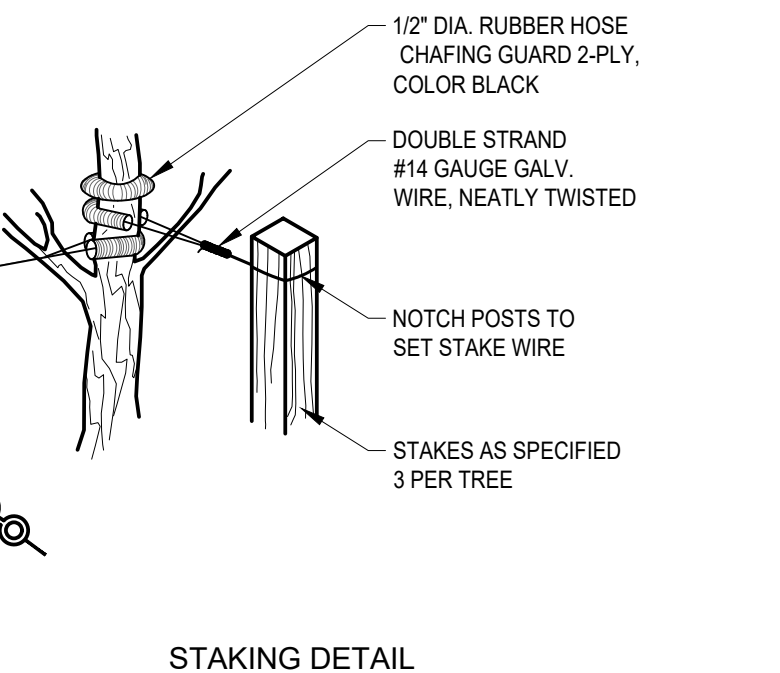

STAKING DETAIL

TREE STAKING AND GUYING SCALE: NTS

WV Group Engineering + Design + Consulting
2879 Param Avenue Hoffman Estates, IL 60132
www.wvgroup.com

COPYRIGHT NOTICE
This drawing is the property of the above referenced Professional and is not to be used for any purpose other than the specific project and site names hereon, and cannot be reproduced in any manner without the express written permission from the Professional.

EVERGREEN DESIGN GROUP
(800) 680-6630
100 E. Campus View Blvd., Suite 250
Columbus, OH 43235
www.EvergreenDesignGroup.com

Table with columns DATE and ISSUE. Row 1: 02/14/2024, OWNER REVIEW SET.

PROFESSIONAL SEAL

STATE OF OHIO
SHARON M STACHECKI
LANDSCAPE ARCHITECT
2101578
02/14/2024

PROFESSIONAL LICENSE NO.
LA-201578

PROFESSIONAL IN CHARGE
SHARON M STACHECKI
PROJECT MANAGER
SS
QUALITY CONTROL
RM/SS
DRAWN BY
SS/AM

PROJECT NAME

Valvoline Instant Oil Change logo

VALVOLINE INSTANT OIL CHANGE
808 COSHOCTON AVENUE
MONROE TOWNSHIP
MOUNT VERNON, OH

PROJECT NUMBER
02300200

SHEET NAME

LANDSCAPE DETAILS AND SPECIFICATIONS

SHEET #

LP-2

Attachment: site plan\_review\_20240213 (3975 : 2024-02-06)

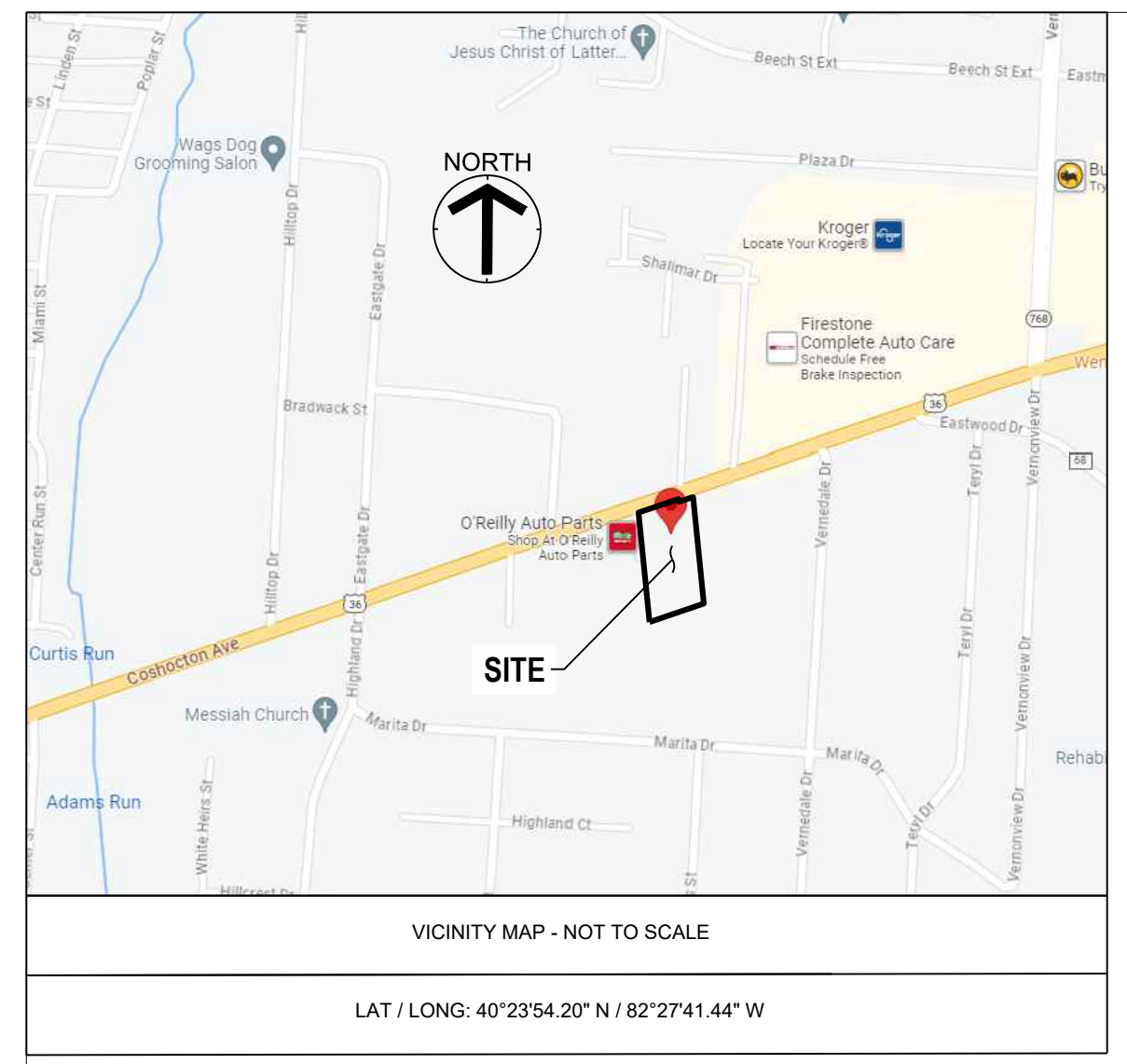

SCHEDULE B - SECTION II

- 10. Deed of Easement to The Ohio Power Company, filed for record April 17, 1936, in Volume 161, Page 498, of the Knox County, Ohio Records. EASEMENT CANNOT BE PLOTTED FROM RECORD DOCUMENT.
11. Deed of Easement to The Ohio Power Company, filed for record May 29, 1936, in Volume 167, Page 50, of the Knox County, Ohio Records. EASEMENT CANNOT BE PLOTTED FROM RECORD DOCUMENT.
12. Deed of Easement to The Ohio Power Company, filed for record July 19, 1940, in Volume 171, Page 610, of the Knox County, Ohio Records. EASEMENT CANNOT BE PLOTTED FROM RECORD DOCUMENT.
13. Deed of Easement to Ohio Power Company, an Ohio Corporation, filed for record October 23, 1947, in Volume 189, Page 369, of the Knox County, Ohio Records. EASEMENT CANNOT BE PLOTTED FROM RECORD DOCUMENT.
14. Deed of Easement to Ohio Power Company, an Ohio Corporation, filed for record March 11, 1966, in Volume 275, Page 523, of the Knox County, Ohio Records. EASEMENT CANNOT BE PLOTTED, OHIO POWER CO. DRAWING WAS NOT PROVIDED.
15. Right-of-Way to Columbia Gas of Ohio, Inc., filed for record June 22, 1966, in Volume 277, Page 346 of the Knox County, Ohio Records. EASEMENT IS ON THE SURVEYED PROPERTY AS SHOWN HEREON.
16. Reservations, restrictions, covenants, limitations, easements, and/or conditions, as established in instrument, filed for record December 22, 2011, in Volume 1316, Page 127, of the Knox County, Ohio Records. LANDS DESCRIBED AS PARCEL 33-WD IN RECORD DOCUMENT ADJOIN THE SURVEYED PROPERTY AS SHOWN HEREON.

EXHIBIT "A" LEGAL DESCRIPTION

Real property in the City of Mount Vernon, County of Knox, State of Ohio, described as follows: Being a part of Lots Numbers Eleven (#11) and Twelve (#12) in Highland Park of record in Plat Book 3, Pages 90 and 91, Recorder's Office Knox County Ohio and beginning at an iron pin in the Northwesterly corner of said Lot Number 11 Highland Park and Southerly Right of Way of Coshocton Avenue (60 feet in width) said point being the Northwesterly corner thereof.
Then North 73 degrees 59 minutes East along the Southerly line of said Coshocton Avenue (passing the Northwesterly corner of Lot Number 12 at a distance of 84.77 feet) a total distance of 115.00 feet to an iron pin in the Northerly line of said Lot Number 12.
Then South 03 degrees 07 minutes, East and parallel to the Westerly line of said Lot Number 11, a distance of 220.00 feet to an iron pin;
Then South 73 degrees 59 minutes West and parallel to Coshocton Avenue a distance of 115.00 feet to an iron pin in the Westerly line of said Lot Number 11;
Then North 03 degrees 07 minutes West along said Westerly line of Lot Number 11 a distance of 220.00 feet to the place of beginning containing 0.566 acres more or less.

ZONING STATEMENT

PER ZONING REPORT: NATIONAL DUE DILIGENCE SERVICES PROJECT # 2318932-46471
DATED: JUNE 30, 2023
CURRENTLY ZONED - GB: GENERAL BUSINESS
BUILDING SETBACK REQUIREMENTS:
MINIMUM FRONT FROM STREET - 30'
MINIMUM CORNER SIDE - N/A
MINIMUM INTERIOR SIDE - 15'
MINIMUM REAR - 15'
HEIGHT RESTRICTIONS:
MAXIMUM (MEASURED IN FEET) - 35'
MAXIMUM (NUMBER OF STORIES) - NONE STATED
AREA REQUIREMENTS:
MINIMUM LOT AREA - NONE
MINIMUM LOT WIDTH (AT BUILDING LINE) - NONE
MINIMUM LOT FRONTAGE (AT RIGHT-OF-WAY) - NONE STATED
PARKING REQUIREMENTS:
1 SPACE / 400 SQ. FT. OF FLOOR AREA PLUS 1 SPACE / EMPLOYEE.

TOPOGRAPHIC LEGEND

- Power / Telephone Pole
Light Pole
Electric Box (Access)
Air Conditioner
Gas Meter
Cleanout
Sanitary Manhole
Storm Manhole
Catch Basin
Catch Basin (Round)
Yard Drain
End Storm Drain
Downspout
Fire Hydrant
Auto-Sprinkler
Water Valve
Monitoring Well
Bollard
Post
Rock
Sign
Bush
Deciduous Tree
Pine Tree
Structure Number

VALVOLINE PARCEL DESCRIPTION

Real property in the City of Mount Vernon, County of Knox, State of Ohio, and being a part of Lot Numbers eleven (#11) and twelve (#12) in Highland Park of record in Plat Book 3, Pages 90 and 91, Recorder's Office Knox County Ohio, and beginning at an Iron Pin in the Northwesterly corner of said Lot Number 11 Highland Park and the southerly right-of-way of Coshocton Avenue (60 feet in width) said point being the northwesterly corner thereof.
Thence with said southerly right of way line of Coshocton Avenue, North 71°22'25" East, a distance of 115.00 feet to a set Iron Pin, and being the True Point of Beginning;
Thence continuing with said right of way line of Coshocton Avenue, the following courses:
• North 71°22'25" East, a distance of 84.59 feet to a set Iron Pin;
• South 09°06'40" East, a distance of 5.81 feet to a found 5/8 inch Iron Pin stamped "ODOT ROW";
• North 71°08'43" East, a distance of 29.97 feet to a found 5/8 inch Iron Pin stamped "ODOT ROW" at the northwest corner of a tract conveyed to First Knox National Bank, as recorded in Book 1299, Pages 663-668;
Thence with the westerly line of said First Knox National Bank, South 05°46'13" East, a distance of 214.25 feet to a set Iron Pin;
Thence with the northerly line of a tract in the name of First Knox National Bank, South 71°22'25" West, a distance of 114.88 feet to a point in the westerly line of a tract conveyed to O'Reilly Auto Enterprises, LLC., as recorded in Book 1456, Pages 779-781 and referenced by a found 1 inch Iron Pin at North 05°46'13" West, a distance of 0.65 feet;
Thence with the westerly line of said O'Reilly Auto Enterprises, LLC., North 05°46'13" West, a distance of 220.00 feet to the True POINT OF BEGINNING.
Containing 0.562 Acres, and being subject to all covenants, restrictions, reservations and easements contained in any instrument of record pertaining to the above described tract of land.

Preliminary
11/03/2023 7:56:00 AM

SURVEYOR'S CERTIFICATION:

To: Valvoline LLC, a Delaware Limited Liability Company and Fidelity National Title Insurance Company

This is to certify that this map or plat and the survey on which it is based were made in accordance with the 2021 Minimum Standard Detail Requirements for ALTA/NSPS Land Title Surveys, jointly established and adopted by ALTA and NSPS, and includes Items 1, 2, 3, 4, 5, 6(a), 6(b), 7(a), 7(b)(1), 8, 9, 11(a)(b), 13, 14, 16, 17, 18, & 20 of Table A thereof. The fieldwork was completed on October 3, 2023.

Date of Plat or Map: 11/01/2023

Steve W. Clutter, Ohio PS No. 7655 Date
clutter@cesoinc.com
175 Montrose West Ave. Suite 400
Akron, OH 44321
(330) 396-5967

SURVEY LEGEND

- 5/8" Iron Pin Set w/cap CESO, Inc
Iron Pin Found as Described
Iron Pipe Found as Described
Railroad Spike Found
Monument Found as Described
PK Nail/Mag Nail Found
PK Nail/Mag Nail Set
Fnd. (F) - Found
Usd. (U) - Used
Obs. (O) - Observed
Rec. (R) - Deed
Calc. (C) - Calculated

LINE TABLE
Line # Direction Length
L1 S09° 06' 40"E 5.81'
L2 N71° 08' 43"E 29.97'
L3 N05° 46' 13"W 5.89'
L4 N71° 07' 58"E 30.32'

SANITARY CHART
SAN. MH. 6021
RIM = 1006.24'
8" CLAY INV.(SW-NE) = 1002.3'
SAN. MH. 6267
RIM = 1019.73'
10" PVC INV.(SW & NE) = 1007.1'
8" CLAY INV.(NE) = 1007.7'
SAN. MH. 6285 (possible grease trap)
RIM = 1021.41'
INV. TO water / sludge = 1017.2'
SAN. MH. 6071
RIM = 1022.4'
(DID NOT DIP)
SAN. MH. 6074
RIM = 1023.1'
(DID NOT DIP)

BENCHMARK
Vertical Datum: NAVD88
derived from GPS Observations

- BM "A": Chisled square set on the northeasterly side of concrete retaining wall. Retaining wall is located on the north side of Coshocton Avenue and across the street from the O'Reilly Auto parts parking lot. Elevation = 1025.53'
BM "B": Benchmark being the northeast bold of concrete light pole base. Light pole is located in the middle of the division wall on the east side of O'Reilly Auto Parts parking lot. Elevation = 1022.78'
BM "C": Benchmark being the northeast bolt of concrete light pole base. Light pole is located in the parking lot island of Park National Bank on the west side of the building. Elevation = 1025.76'

SURVEYOR NOTES:

- 1. This survey does not constitute a title search by the surveyor. All information regarding record easements, and other documents that might affect the quality of title to the parcel shown hereon we obtained through a certified title commitment conducted by Fidelity National Title Insurance Company, Commitment Number GLW2300955 and bearing an effective date of June 13, 2023 at 6:59 AM.
2. Direct access to the subject parcel is available via Coshocton Avenue (Aka U.S. 36). No roadway improvement plans were disclosed to CESO during the survey.
3. The utilities shown are located from field survey information and/or existing drawings supplied by client. The surveyor makes no guarantee that the utilities located comprise all such utilities in the area, either in service or abandoned. The surveyor further does not warrant that the utilities located are in the exact location indicated although the surveyor does certify that they are located as accurately as possible from information available.
Utilities located by Underground Detective on September 5, 2023.
OUPS Ticket #: A327600449-00A
4. Parcel is located within Zone "X" (Area of minimal flood hazard) as indicated by the Flood Insurance Rate Map (FIRM) Map Number 39083C0189D, effective date: July 7, 2023 published by the Federal Emergency Management Agency.
5. There are no visible parking spots on the surveyed property.
6. The closest intersection is Edgewood Blvd and Coshocton Ave, located approximately 453' southwest of the site.
7. There was no observed evidence of current earth moving work, building construction or building additions at the time of this survey.
8. No proposed changes in street right of way lines were provided to the surveyor. No evidence of street or sidewalk construction or repairs observed at time of survey.

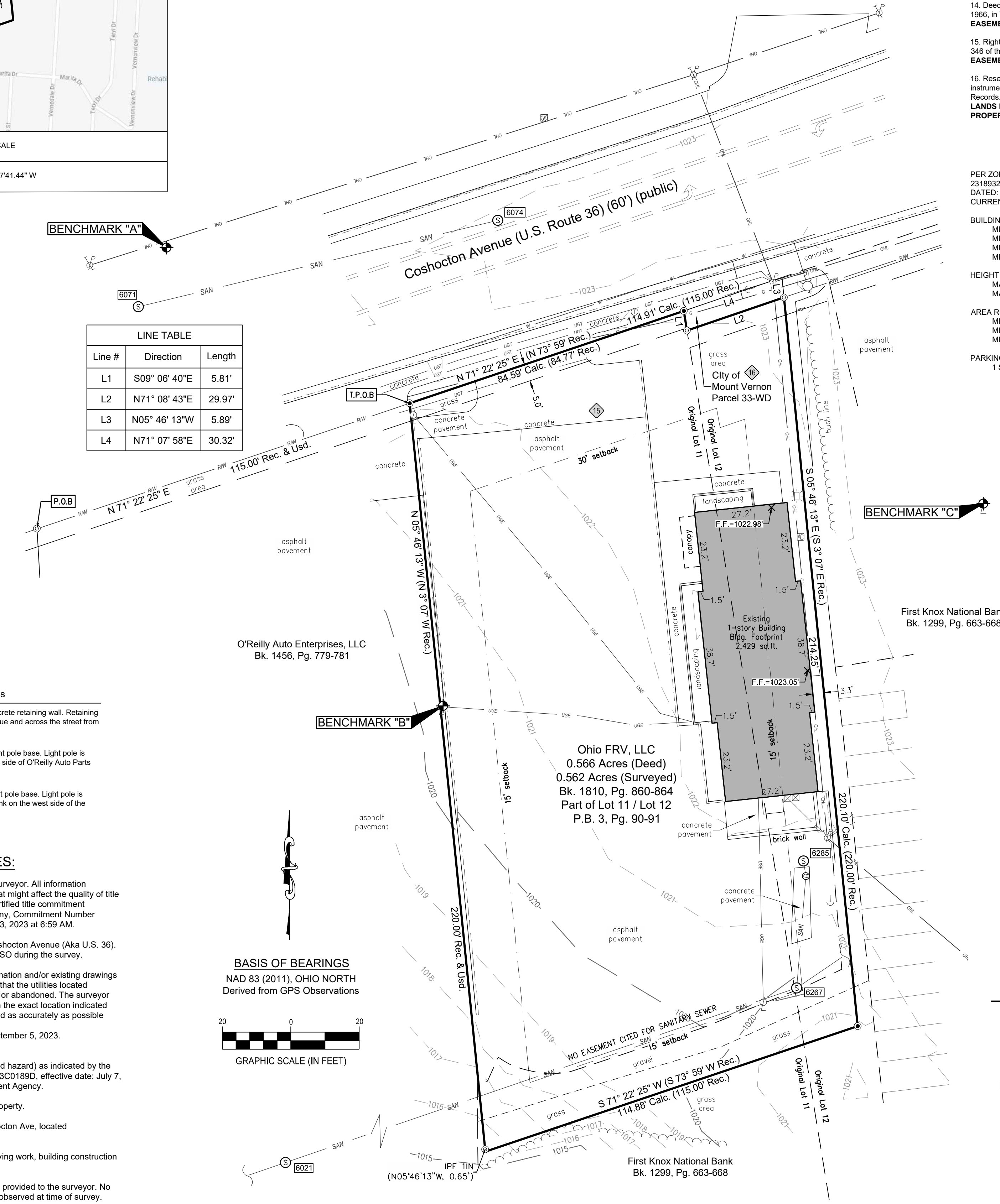
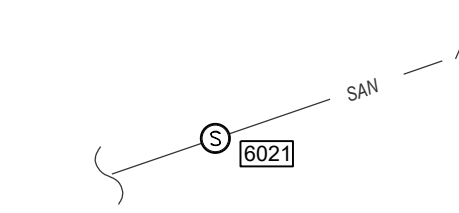
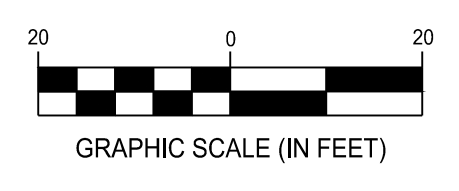
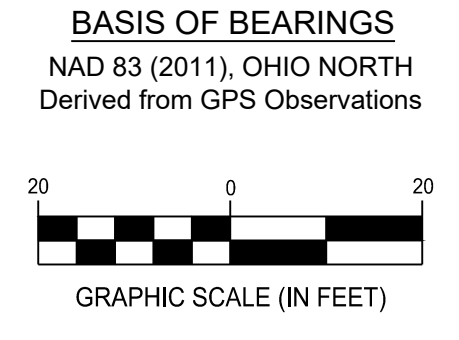

Valvoline

Mt. Vernon, Ohio
808 Coshocton Avenue
County of Knox, Monroe Township, City of Mount Vernon
Section 25, Town 7, Range 12

Revisions / Submissions

Table with columns: ID, Description, Date

Project Number: 763102
Scale: 1" = 20'
Drawn By: RSL
Checked By: STB
Date: 10/16/2023
Issue: ALTA SURVEY

Drawing Title:
ALTA / NSPS LAND
TITLE SURVEY

W:\PROJECTS\VALVOLINE\763102 - Mt. Vernon, OH\04-SURVEY\DWG\763102\_VIOC\_Mt\_Vernon\_surr-xxxx.dwg - 11/3/2023 - Steve Clutter

Attachment: site\_plan\_review\_20240213 (8975 - 2024-Bza-06)